

April 2019



**OMATION**<sup>®</sup>  
SERIES 410 ENVELOPENER<sup>®</sup>

## OMATION<sup>®</sup> Series 410 Envelopener<sup>™</sup> Operator Manual

92869100M-EN

Revision 19-01

Original Instructions

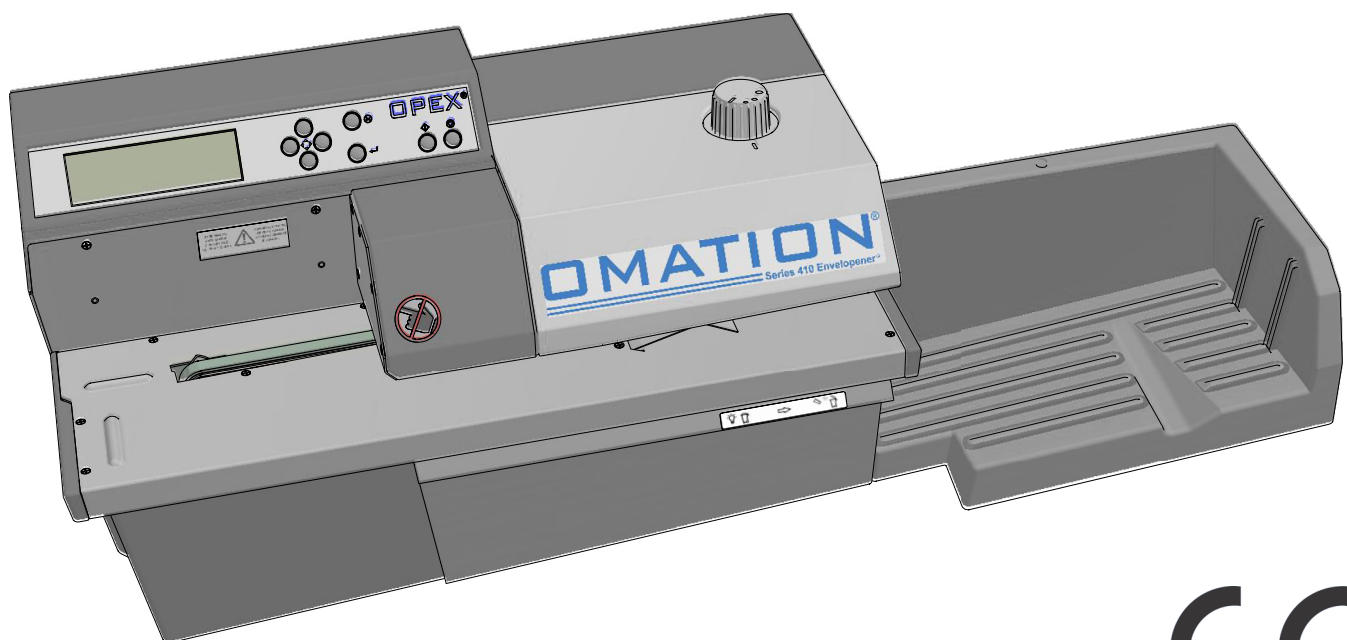

OMATION<sup>®</sup> Series 410 Envelopener<sup>™</sup>



### WARNING

Read this manual thoroughly before attempting to operate or service this equipment. Keep a current copy for your reference.

© 2019 OPEX<sup>®</sup> Corporation

All rights reserved. This document is provided by OPEX for use by their customers, partners and dealers. No portion of these materials may be reproduced, published, or stored in a database or retrieval system, other than for its intended use without the express, written consent of OPEX Corporation.

---

---

## 0.1. Contacting OPEX

---

---

### **For technical support:**

OPEX Technical Support  
835 Lancer Drive  
Moorestown, NJ 08057 USA

Americas: 1 800.673.9288 -OR- 856.727.1950

EMEA: +1 800.673.9288

Australia: +1 800.945247

<https://www.opex.com/support-service>

Please have the model name and serial number of the product ready (see [“Equipment Model/Serial Number Locations” on page 30](#)).

### **For other inquiries:**

OPEX® Corporation  
305 Commerce Dr.  
Moorestown, NJ 08057-4234 USA

Tel: +1 856.727.1100

Fax: +1 856.727.1955

<https://www.opex.com/>

If you find errors, inaccuracies, or any other issues or concerns with this document, please contact the OPEX Technical Writers via email at:

[GroupTechwriters@opex.com](mailto:GroupTechwriters@opex.com)

For help with opexservice website-related issues, please contact the OPEX Web Developers via email at: [GroupWebDev@opex.com](mailto:GroupWebDev@opex.com)

## 0.2. EU Declaration of Conformity

### 0.2.1. EU Declaration of Conformity Australia: AU

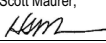
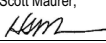
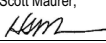
		<b>EU Declaration of Conformity</b> <b>OM410</b> This declaration of conformity is issued under the sole responsibility of the manufacturer.																		
1.0	Manufacturer	<table border="1"> <tr> <td>NAME</td> <td>OPEX Corporation</td> </tr> <tr> <td>ADDRESS</td> <td>835 Lancer Drive, Moorestown, NJ 08057, USA</td> </tr> </table>	NAME	OPEX Corporation	ADDRESS	835 Lancer Drive, Moorestown, NJ 08057, USA														
NAME	OPEX Corporation																			
ADDRESS	835 Lancer Drive, Moorestown, NJ 08057, USA																			
2.0	Technical File	Technical documentation is compiled in accordance with Part B of Annex VII of the machinery directive. This documentation is available on a reasoned request by appropriate national authority to our authorized representative: <table border="1"> <tr> <td>NAME</td> <td>OPEX Business Machines Pty Ltd</td> </tr> <tr> <td>ADDRESS</td> <td>Level 12, 225 George Street Sydney, NSW 2000 Australia</td> </tr> </table>	NAME	OPEX Business Machines Pty Ltd	ADDRESS	Level 12, 225 George Street Sydney, NSW 2000 Australia														
NAME	OPEX Business Machines Pty Ltd																			
ADDRESS	Level 12, 225 George Street Sydney, NSW 2000 Australia																			
3.0	Description and identification	<table border="1"> <tr> <td>Description</td> <td>Envelope Opener</td> </tr> <tr> <td>Model</td> <td>OM410</td> </tr> <tr> <td>Serial Number</td> <td></td> </tr> <tr> <td>Year Manufactured</td> <td>From 2019</td> </tr> </table>	Description	Envelope Opener	Model	OM410	Serial Number		Year Manufactured	From 2019										
Description	Envelope Opener																			
Model	OM410																			
Serial Number																				
Year Manufactured	From 2019																			
4.0	Directives	<table border="1"> <tr> <td>2014/35/EU</td> <td>Low Voltage Directive</td> </tr> <tr> <td>2014/30/EU</td> <td>Electromagnetic Compatibility Directive</td> </tr> <tr> <td>2011/65/EU</td> <td>RoHS 2 Directive</td> </tr> <tr> <td>2015/863/EU</td> <td>RoHS 3 amendment</td> </tr> </table>	2014/35/EU	Low Voltage Directive	2014/30/EU	Electromagnetic Compatibility Directive	2011/65/EU	RoHS 2 Directive	2015/863/EU	RoHS 3 amendment										
2014/35/EU	Low Voltage Directive																			
2014/30/EU	Electromagnetic Compatibility Directive																			
2011/65/EU	RoHS 2 Directive																			
2015/863/EU	RoHS 3 amendment																			
5.0	Certified Body	<table border="1"> <tr> <td></td> <td>Intertek Testing Services NA, Inc. 70 Codman Hill Rd. Boxborough MA 01719 USA</td> </tr> </table>		Intertek Testing Services NA, Inc. 70 Codman Hill Rd. Boxborough MA 01719 USA																
	Intertek Testing Services NA, Inc. 70 Codman Hill Rd. Boxborough MA 01719 USA																			
6.0	Harmonized Standards used	<table border="1"> <tr> <td>IEC 62368-1:2014Ed.2+C1</td> <td>Audio/video, information and communication technology equipment Part 1: Safety requirements</td> </tr> <tr> <td>IEC 61000-3-2:2014</td> <td>Harmonics</td> </tr> <tr> <td>IEC 61000-3-3:2013</td> <td>Flicker</td> </tr> <tr> <td>IEC 61000-4-2:2008</td> <td>Electro-Static Discharge Immunity Test</td> </tr> <tr> <td>IEC 61000-4-3:2006, IEC 61000-4-3:2006/AMD1:2007 IEC 610004-3:2006/AMD2:2010</td> <td>Radiated, Radio-Frequency, Electromagnetic Immunity</td> </tr> <tr> <td>IEC 61000-4-4:2012</td> <td>Electrical Fast Transient/Burst Immunity Test</td> </tr> <tr> <td>IEC 61000-4-5:2014</td> <td>Immunity to Surges</td> </tr> <tr> <td>IEC 61000-4-6:2013</td> <td>Conducted, Radio-Frequency, Electromagnetic Immunity Test</td> </tr> <tr> <td>IEC 61000-4-11:2004</td> <td>Voltage Dips/Interruptions Immunity Test</td> </tr> </table>	IEC 62368-1:2014Ed.2+C1	Audio/video, information and communication technology equipment Part 1: Safety requirements	IEC 61000-3-2:2014	Harmonics	IEC 61000-3-3:2013	Flicker	IEC 61000-4-2:2008	Electro-Static Discharge Immunity Test	IEC 61000-4-3:2006, IEC 61000-4-3:2006/AMD1:2007 IEC 610004-3:2006/AMD2:2010	Radiated, Radio-Frequency, Electromagnetic Immunity	IEC 61000-4-4:2012	Electrical Fast Transient/Burst Immunity Test	IEC 61000-4-5:2014	Immunity to Surges	IEC 61000-4-6:2013	Conducted, Radio-Frequency, Electromagnetic Immunity Test	IEC 61000-4-11:2004	Voltage Dips/Interruptions Immunity Test
IEC 62368-1:2014Ed.2+C1	Audio/video, information and communication technology equipment Part 1: Safety requirements																			
IEC 61000-3-2:2014	Harmonics																			
IEC 61000-3-3:2013	Flicker																			
IEC 61000-4-2:2008	Electro-Static Discharge Immunity Test																			
IEC 61000-4-3:2006, IEC 61000-4-3:2006/AMD1:2007 IEC 610004-3:2006/AMD2:2010	Radiated, Radio-Frequency, Electromagnetic Immunity																			
IEC 61000-4-4:2012	Electrical Fast Transient/Burst Immunity Test																			
IEC 61000-4-5:2014	Immunity to Surges																			
IEC 61000-4-6:2013	Conducted, Radio-Frequency, Electromagnetic Immunity Test																			
IEC 61000-4-11:2004	Voltage Dips/Interruptions Immunity Test																			
7.0	Technical Standards used	<table border="1"> <tr> <td>UL 62368-1:2014 Ed.2</td> <td>Audio/Video, Information And Communication Technology Equipment - Part 1: Safety Requirements</td> </tr> <tr> <td>CSA C22.2#62368-1:2014 Ed.2</td> <td>Audio/Video, Information And Communication Technology Equipment - Part 1: Safety Requirements</td> </tr> <tr> <td>CISPR 32 Ed 2.0:2015</td> <td>Radiated Emissions, AC Mains Conducted Emissions Electromagnetic Compatibility Of Multimedia Equipment - Emission Requirements</td> </tr> <tr> <td>FCC 47CFR PT 15 Sub Part B: April 16, 2019</td> <td>Radiated Emissions, AC Mains Conducted Emissions Unintentional Radiator</td> </tr> <tr> <td>ISO 7779 Issued:1999/08/01</td> <td>Acoustics - Measurement of Airborne Noise Emitted by Information Technology and Telecommunications Equipment-Second Edition; Amendment 1: 3/01/2003</td> </tr> </table>	UL 62368-1:2014 Ed.2	Audio/Video, Information And Communication Technology Equipment - Part 1: Safety Requirements	CSA C22.2#62368-1:2014 Ed.2	Audio/Video, Information And Communication Technology Equipment - Part 1: Safety Requirements	CISPR 32 Ed 2.0:2015	Radiated Emissions, AC Mains Conducted Emissions Electromagnetic Compatibility Of Multimedia Equipment - Emission Requirements	FCC 47CFR PT 15 Sub Part B: April 16, 2019	Radiated Emissions, AC Mains Conducted Emissions Unintentional Radiator	ISO 7779 Issued:1999/08/01	Acoustics - Measurement of Airborne Noise Emitted by Information Technology and Telecommunications Equipment-Second Edition; Amendment 1: 3/01/2003								
UL 62368-1:2014 Ed.2	Audio/Video, Information And Communication Technology Equipment - Part 1: Safety Requirements																			
CSA C22.2#62368-1:2014 Ed.2	Audio/Video, Information And Communication Technology Equipment - Part 1: Safety Requirements																			
CISPR 32 Ed 2.0:2015	Radiated Emissions, AC Mains Conducted Emissions Electromagnetic Compatibility Of Multimedia Equipment - Emission Requirements																			
FCC 47CFR PT 15 Sub Part B: April 16, 2019	Radiated Emissions, AC Mains Conducted Emissions Unintentional Radiator																			
ISO 7779 Issued:1999/08/01	Acoustics - Measurement of Airborne Noise Emitted by Information Technology and Telecommunications Equipment-Second Edition; Amendment 1: 3/01/2003																			
8.0	Approval	I, the undersigned, hereby declare that the equipment specified above conforms to the above Directive(s) and Standard(s). <table border="1"> <tr> <td>Place of issue</td> <td>Moorestown, NJ, USA</td> </tr> <tr> <td>Date of issue</td> <td>Apr 24, 2019</td> </tr> <tr> <td>Authorized</td> <td>Scott Maurer, </td> </tr> <tr> <td>Title</td> <td>President, International Division</td> </tr> </table>	Place of issue	Moorestown, NJ, USA	Date of issue	Apr 24, 2019	Authorized	Scott Maurer, 	Title	President, International Division										
Place of issue	Moorestown, NJ, USA																			
Date of issue	Apr 24, 2019																			
Authorized	Scott Maurer, 																			
Title	President, International Division																			
Drawing: 92801xx-DoC-AU		Revision: 0.1																		

## 0.2.2. EU Declaration of Conformity France: FR

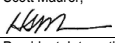
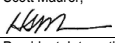
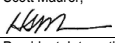
		<b>EU Declaration of Conformity</b> <b>OM410</b>																		
This declaration of conformity is issued under the sole responsibility of the manufacturer.																				
<b>1.0</b>	<b>Manufacturer</b>	<table border="1"> <tr> <td>NAME</td> <td>OPEX Corporation</td> </tr> <tr> <td>ADDRESS</td> <td>835 Lancer Drive, Moorestown, NJ 08057, USA</td> </tr> </table>	NAME	OPEX Corporation	ADDRESS	835 Lancer Drive, Moorestown, NJ 08057, USA														
NAME	OPEX Corporation																			
ADDRESS	835 Lancer Drive, Moorestown, NJ 08057, USA																			
<b>2.0</b>	<b>Technical File</b>	Technical documentation is compiled in accordance with Part B of Annex VII of the machinery directive. This documentation is available on a reasoned request by appropriate national authority to our authorized representative:																		
		<table border="1"> <tr> <td>NAME</td> <td>OPEX Corporation</td> </tr> <tr> <td>ADDRESS</td> <td>Les Fjords - Bâtiment Vega 19, avenue de Norvège ZA de Courtaboeuf 91140 Villebon-sur-Yvette, France</td> </tr> </table>	NAME	OPEX Corporation	ADDRESS	Les Fjords - Bâtiment Vega 19, avenue de Norvège ZA de Courtaboeuf 91140 Villebon-sur-Yvette, France														
NAME	OPEX Corporation																			
ADDRESS	Les Fjords - Bâtiment Vega 19, avenue de Norvège ZA de Courtaboeuf 91140 Villebon-sur-Yvette, France																			
<b>3.0</b>	<b>Description and identification</b>	<table border="1"> <tr> <td>Description</td> <td>Envelope Opener</td> </tr> <tr> <td>Model</td> <td>OM410</td> </tr> <tr> <td>Serial Number</td> <td></td> </tr> <tr> <td>Year Manufactured</td> <td>From 2019</td> </tr> </table>	Description	Envelope Opener	Model	OM410	Serial Number		Year Manufactured	From 2019										
Description	Envelope Opener																			
Model	OM410																			
Serial Number																				
Year Manufactured	From 2019																			
<b>4.0</b>	<b>Directives</b>	<table border="1"> <tr> <td>2014/35/EU</td> <td>Low Voltage Directive</td> </tr> <tr> <td>2014/30/EU</td> <td>Electromagnetic Compatibility Directive</td> </tr> <tr> <td>2011/65/EU</td> <td>RoHS 2 Directive</td> </tr> <tr> <td>2015/863/EU</td> <td>RoHS 3 amendment</td> </tr> </table>	2014/35/EU	Low Voltage Directive	2014/30/EU	Electromagnetic Compatibility Directive	2011/65/EU	RoHS 2 Directive	2015/863/EU	RoHS 3 amendment										
2014/35/EU	Low Voltage Directive																			
2014/30/EU	Electromagnetic Compatibility Directive																			
2011/65/EU	RoHS 2 Directive																			
2015/863/EU	RoHS 3 amendment																			
<b>5.0</b>	<b>Certified Body</b>	<table border="1"> <tr> <td></td> <td>Intertek Testing Services NA, Inc. 70 Codman Hill Rd. Boxborough MA 01719 USA</td> </tr> </table>		Intertek Testing Services NA, Inc. 70 Codman Hill Rd. Boxborough MA 01719 USA																
	Intertek Testing Services NA, Inc. 70 Codman Hill Rd. Boxborough MA 01719 USA																			
<b>6.0</b>	<b>Harmonized Standards used</b>	<table border="1"> <tr> <td>IEC 62368-1:2014Ed.2+C1</td> <td>Audio/video, information and communication technology equipment Part 1: Safety requirements</td> </tr> <tr> <td>IEC 61000-3-2:2014</td> <td>Harmonics</td> </tr> <tr> <td>IEC 61000-3-3:2013</td> <td>Flicker</td> </tr> <tr> <td>IEC 61000-4-2:2008</td> <td>Electro-Static Discharge Immunity Test</td> </tr> <tr> <td>IEC 61000-4-3:2006, IEC 61000-4-3:2006/AMD1:2007 IEC 610004-3:2006/AMD2:2010</td> <td>Radiated, Radio-Frequency, Electromagnetic Immunity</td> </tr> <tr> <td>IEC 61000-4-4:2012</td> <td>Electrical Fast Transient/Burst Immunity Test</td> </tr> <tr> <td>IEC 61000-4-5:2014</td> <td>Immunity to Surges</td> </tr> <tr> <td>IEC 61000-4-6:2013</td> <td>Conducted, Radio-Frequency, Electromagnetic Immunity Test</td> </tr> <tr> <td>IEC 61000-4-11:2004</td> <td>Voltage Dips/Interruptions Immunity Test</td> </tr> </table>	IEC 62368-1:2014Ed.2+C1	Audio/video, information and communication technology equipment Part 1: Safety requirements	IEC 61000-3-2:2014	Harmonics	IEC 61000-3-3:2013	Flicker	IEC 61000-4-2:2008	Electro-Static Discharge Immunity Test	IEC 61000-4-3:2006, IEC 61000-4-3:2006/AMD1:2007 IEC 610004-3:2006/AMD2:2010	Radiated, Radio-Frequency, Electromagnetic Immunity	IEC 61000-4-4:2012	Electrical Fast Transient/Burst Immunity Test	IEC 61000-4-5:2014	Immunity to Surges	IEC 61000-4-6:2013	Conducted, Radio-Frequency, Electromagnetic Immunity Test	IEC 61000-4-11:2004	Voltage Dips/Interruptions Immunity Test
IEC 62368-1:2014Ed.2+C1	Audio/video, information and communication technology equipment Part 1: Safety requirements																			
IEC 61000-3-2:2014	Harmonics																			
IEC 61000-3-3:2013	Flicker																			
IEC 61000-4-2:2008	Electro-Static Discharge Immunity Test																			
IEC 61000-4-3:2006, IEC 61000-4-3:2006/AMD1:2007 IEC 610004-3:2006/AMD2:2010	Radiated, Radio-Frequency, Electromagnetic Immunity																			
IEC 61000-4-4:2012	Electrical Fast Transient/Burst Immunity Test																			
IEC 61000-4-5:2014	Immunity to Surges																			
IEC 61000-4-6:2013	Conducted, Radio-Frequency, Electromagnetic Immunity Test																			
IEC 61000-4-11:2004	Voltage Dips/Interruptions Immunity Test																			
<b>7.0</b>	<b>Technical Standards used</b>	<table border="1"> <tr> <td>UL 62368-1:2014 Ed.2</td> <td>Audio/Video, Information And Communication Technology Equipment - Part 1: Safety Requirements</td> </tr> <tr> <td>CSA C22.2#62368-1:2014 Ed.2</td> <td>Audio/Video, Information And Communication Technology Equipment - Part 1: Safety Requirements</td> </tr> <tr> <td>CISPR 32 Ed 2.0:2015</td> <td>Radiated Emissions, AC Mains Conducted Emissions Electromagnetic Compatibility Of Multimedia Equipment - Emission Requirements</td> </tr> <tr> <td>FCC 47CFR PT 15 Sub Part B: April 16, 2019</td> <td>Radiated Emissions, AC Mains Conducted Emissions Unintentional Radiator</td> </tr> <tr> <td>ISO 7779 Issued:1999/08/01</td> <td>Acoustics - Measurement of Airborne Noise Emitted by Information Technology and Telecommunications Equipment-Second Edition; Amendment 1: 3/01/2003</td> </tr> </table>	UL 62368-1:2014 Ed.2	Audio/Video, Information And Communication Technology Equipment - Part 1: Safety Requirements	CSA C22.2#62368-1:2014 Ed.2	Audio/Video, Information And Communication Technology Equipment - Part 1: Safety Requirements	CISPR 32 Ed 2.0:2015	Radiated Emissions, AC Mains Conducted Emissions Electromagnetic Compatibility Of Multimedia Equipment - Emission Requirements	FCC 47CFR PT 15 Sub Part B: April 16, 2019	Radiated Emissions, AC Mains Conducted Emissions Unintentional Radiator	ISO 7779 Issued:1999/08/01	Acoustics - Measurement of Airborne Noise Emitted by Information Technology and Telecommunications Equipment-Second Edition; Amendment 1: 3/01/2003								
UL 62368-1:2014 Ed.2	Audio/Video, Information And Communication Technology Equipment - Part 1: Safety Requirements																			
CSA C22.2#62368-1:2014 Ed.2	Audio/Video, Information And Communication Technology Equipment - Part 1: Safety Requirements																			
CISPR 32 Ed 2.0:2015	Radiated Emissions, AC Mains Conducted Emissions Electromagnetic Compatibility Of Multimedia Equipment - Emission Requirements																			
FCC 47CFR PT 15 Sub Part B: April 16, 2019	Radiated Emissions, AC Mains Conducted Emissions Unintentional Radiator																			
ISO 7779 Issued:1999/08/01	Acoustics - Measurement of Airborne Noise Emitted by Information Technology and Telecommunications Equipment-Second Edition; Amendment 1: 3/01/2003																			
<b>8.0</b>	<b>Approval</b>	I, the undersigned, hereby declare that the equipment specified above conforms to the above Directive(s) and Standard(s).																		
		<table border="1"> <tr> <td>Place of issue</td> <td>Moorestown, NJ, USA</td> </tr> <tr> <td>Date of issue</td> <td>Apr 24, 2019</td> </tr> <tr> <td>Authorized</td> <td>Scott Maurer, </td> </tr> <tr> <td>Title</td> <td>President, International Division</td> </tr> </table>	Place of issue	Moorestown, NJ, USA	Date of issue	Apr 24, 2019	Authorized	Scott Maurer, 	Title	President, International Division										
Place of issue	Moorestown, NJ, USA																			
Date of issue	Apr 24, 2019																			
Authorized	Scott Maurer, 																			
Title	President, International Division																			
Drawing: 92801xx-DoC-FR		Revision: 0.1																		

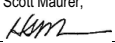
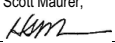
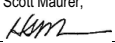

## 0.2.3. EU Declaration of Conformity Germany: GR

		<b>EU Declaration of Conformity</b> <b>OM410</b>																		
This declaration of conformity is issued under the sole responsibility of the manufacturer.																				
1.0	Manufacturer	<table border="1"> <tr> <td>NAME</td> <td>OPEX Corporation</td> </tr> <tr> <td>ADDRESS</td> <td>835 Lancer Drive, Moorestown, NJ 08057, USA</td> </tr> </table>	NAME	OPEX Corporation	ADDRESS	835 Lancer Drive, Moorestown, NJ 08057, USA														
NAME	OPEX Corporation																			
ADDRESS	835 Lancer Drive, Moorestown, NJ 08057, USA																			
2.0	Technical File	Technical documentation is compiled in accordance with Part B of Annex VII of the machinery directive. This documentation is available on a reasoned request by appropriate national authority to our authorized representative:																		
		<table border="1"> <tr> <td>NAME</td> <td>OPEX Corporation</td> </tr> <tr> <td>ADDRESS</td> <td>Auf der Lug 8 71726 Benningen am Neckar Germany</td> </tr> </table>	NAME	OPEX Corporation	ADDRESS	Auf der Lug 8 71726 Benningen am Neckar Germany														
NAME	OPEX Corporation																			
ADDRESS	Auf der Lug 8 71726 Benningen am Neckar Germany																			
3.0	Description and identification	<table border="1"> <tr> <td>Description</td> <td>Envelope Opener</td> </tr> <tr> <td>Model</td> <td>OM410</td> </tr> <tr> <td>Serial Number</td> <td></td> </tr> <tr> <td>Year Manufactured</td> <td>From 2019</td> </tr> </table>	Description	Envelope Opener	Model	OM410	Serial Number		Year Manufactured	From 2019										
Description	Envelope Opener																			
Model	OM410																			
Serial Number																				
Year Manufactured	From 2019																			
4.0	Directives	<table border="1"> <tr> <td>2014/35/EU</td> <td>Low Voltage Directive</td> </tr> <tr> <td>2014/30/EU</td> <td>Electromagnetic Compatibility Directive</td> </tr> <tr> <td>2011/65/EU</td> <td>RoHS 2 Directive</td> </tr> <tr> <td>2015/863/EU</td> <td>RoHS 3 amendment</td> </tr> </table>	2014/35/EU	Low Voltage Directive	2014/30/EU	Electromagnetic Compatibility Directive	2011/65/EU	RoHS 2 Directive	2015/863/EU	RoHS 3 amendment										
2014/35/EU	Low Voltage Directive																			
2014/30/EU	Electromagnetic Compatibility Directive																			
2011/65/EU	RoHS 2 Directive																			
2015/863/EU	RoHS 3 amendment																			
5.0	Certified Body	<table border="1"> <tr> <td></td> <td>Intertek Testing Services NA, Inc. 70 Codman Hill Rd. Boxborough MA 01719 USA</td> </tr> </table>		Intertek Testing Services NA, Inc. 70 Codman Hill Rd. Boxborough MA 01719 USA																
	Intertek Testing Services NA, Inc. 70 Codman Hill Rd. Boxborough MA 01719 USA																			
6.0	Harmonized Standards used	<table border="1"> <tr> <td>IEC 62368-1:2014Ed.2+C1</td> <td>Audio/video, information and communication technology equipment Part 1: Safety requirements</td> </tr> <tr> <td>IEC 61000-3-2:2014</td> <td>Harmonics</td> </tr> <tr> <td>IEC 61000-3-3:2013</td> <td>Flicker</td> </tr> <tr> <td>IEC 61000-4-2:2008</td> <td>Electro-Static Discharge Immunity Test</td> </tr> <tr> <td>IEC 61000-4-3:2006, IEC 61000-4-3:2006/AMD1:2007 IEC 610004-3:2006/AMD2:2010</td> <td>Radiated, Radio-Frequency, Electromagnetic Immunity</td> </tr> <tr> <td>IEC 61000-4-4:2012</td> <td>Electrical Fast Transient/Burst Immunity Test</td> </tr> <tr> <td>IEC 61000-4-5:2014</td> <td>Immunity to Surges</td> </tr> <tr> <td>IEC 61000-4-6:2013</td> <td>Conducted, Radio-Frequency, Electromagnetic Immunity Test</td> </tr> <tr> <td>IEC 61000-4-11:2004</td> <td>Voltage Dips/Interruptions Immunity Test</td> </tr> </table>	IEC 62368-1:2014Ed.2+C1	Audio/video, information and communication technology equipment Part 1: Safety requirements	IEC 61000-3-2:2014	Harmonics	IEC 61000-3-3:2013	Flicker	IEC 61000-4-2:2008	Electro-Static Discharge Immunity Test	IEC 61000-4-3:2006, IEC 61000-4-3:2006/AMD1:2007 IEC 610004-3:2006/AMD2:2010	Radiated, Radio-Frequency, Electromagnetic Immunity	IEC 61000-4-4:2012	Electrical Fast Transient/Burst Immunity Test	IEC 61000-4-5:2014	Immunity to Surges	IEC 61000-4-6:2013	Conducted, Radio-Frequency, Electromagnetic Immunity Test	IEC 61000-4-11:2004	Voltage Dips/Interruptions Immunity Test
IEC 62368-1:2014Ed.2+C1	Audio/video, information and communication technology equipment Part 1: Safety requirements																			
IEC 61000-3-2:2014	Harmonics																			
IEC 61000-3-3:2013	Flicker																			
IEC 61000-4-2:2008	Electro-Static Discharge Immunity Test																			
IEC 61000-4-3:2006, IEC 61000-4-3:2006/AMD1:2007 IEC 610004-3:2006/AMD2:2010	Radiated, Radio-Frequency, Electromagnetic Immunity																			
IEC 61000-4-4:2012	Electrical Fast Transient/Burst Immunity Test																			
IEC 61000-4-5:2014	Immunity to Surges																			
IEC 61000-4-6:2013	Conducted, Radio-Frequency, Electromagnetic Immunity Test																			
IEC 61000-4-11:2004	Voltage Dips/Interruptions Immunity Test																			
7.0	Technical Standards used	<table border="1"> <tr> <td>UL 62368-1:2014 Ed.2</td> <td>Audio/Video, Information And Communication Technology Equipment - Part 1: Safety Requirements</td> </tr> <tr> <td>CSA C22.2#62368-1:2014 Ed.2</td> <td>Audio/Video, Information And Communication Technology Equipment - Part 1: Safety Requirements</td> </tr> <tr> <td>CISPR 32 Ed 2.0:2015</td> <td>Radiated Emissions, AC Mains Conducted Emissions Electromagnetic Compatibility Of Multimedia Equipment - Emission Requirements</td> </tr> <tr> <td>FCC 47CFR PT 15 Sub Part B: April 16, 2019</td> <td>Radiated Emissions, AC Mains Conducted Emissions Unintentional Radiator</td> </tr> <tr> <td>ISO 7779 Issued:1999/08/01</td> <td>Acoustics - Measurement of Airborne Noise Emitted by Information Technology and Telecommunications Equipment-Second Edition; Amendment 1: 3/01/2003</td> </tr> </table>	UL 62368-1:2014 Ed.2	Audio/Video, Information And Communication Technology Equipment - Part 1: Safety Requirements	CSA C22.2#62368-1:2014 Ed.2	Audio/Video, Information And Communication Technology Equipment - Part 1: Safety Requirements	CISPR 32 Ed 2.0:2015	Radiated Emissions, AC Mains Conducted Emissions Electromagnetic Compatibility Of Multimedia Equipment - Emission Requirements	FCC 47CFR PT 15 Sub Part B: April 16, 2019	Radiated Emissions, AC Mains Conducted Emissions Unintentional Radiator	ISO 7779 Issued:1999/08/01	Acoustics - Measurement of Airborne Noise Emitted by Information Technology and Telecommunications Equipment-Second Edition; Amendment 1: 3/01/2003								
UL 62368-1:2014 Ed.2	Audio/Video, Information And Communication Technology Equipment - Part 1: Safety Requirements																			
CSA C22.2#62368-1:2014 Ed.2	Audio/Video, Information And Communication Technology Equipment - Part 1: Safety Requirements																			
CISPR 32 Ed 2.0:2015	Radiated Emissions, AC Mains Conducted Emissions Electromagnetic Compatibility Of Multimedia Equipment - Emission Requirements																			
FCC 47CFR PT 15 Sub Part B: April 16, 2019	Radiated Emissions, AC Mains Conducted Emissions Unintentional Radiator																			
ISO 7779 Issued:1999/08/01	Acoustics - Measurement of Airborne Noise Emitted by Information Technology and Telecommunications Equipment-Second Edition; Amendment 1: 3/01/2003																			
8.0	Approval	I, the undersigned, hereby declare that the equipment specified above conforms to the above Directive(s) and Standard(s).																		
		<table border="1"> <tr> <td>Place of issue</td> <td>Moorestown, NJ, USA</td> </tr> <tr> <td>Date of issue</td> <td>Apr 24, 2019</td> </tr> <tr> <td>Authorized</td> <td>Scott Maurer, </td> </tr> <tr> <td>Title</td> <td>President, International Division</td> </tr> </table>	Place of issue	Moorestown, NJ, USA	Date of issue	Apr 24, 2019	Authorized	Scott Maurer, 	Title	President, International Division										
Place of issue	Moorestown, NJ, USA																			
Date of issue	Apr 24, 2019																			
Authorized	Scott Maurer, 																			
Title	President, International Division																			
Drawing: 92801xx-DoC-GR		Revision: 0.1																		

# 0.2.4. EU Declaration of Conformity Republic of Ireland: IR

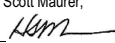
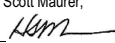
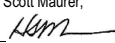
		<b>EU Declaration of Conformity</b> <b>OM410</b>																		
This declaration of conformity is issued under the sole responsibility of the manufacturer.																				
1.0	Manufacturer	<table border="1"> <tr> <td>NAME</td> <td>OPEX Corporation</td> </tr> <tr> <td>ADDRESS</td> <td>835 Lancer Drive, Moorestown, NJ 08057, USA</td> </tr> </table>	NAME	OPEX Corporation	ADDRESS	835 Lancer Drive, Moorestown, NJ 08057, USA														
NAME	OPEX Corporation																			
ADDRESS	835 Lancer Drive, Moorestown, NJ 08057, USA																			
2.0	Technical File	Technical documentation is compiled in accordance with Part B of Annex VII of the machinery directive. This documentation is available on a reasoned request by appropriate national authority to our authorized representative: <table border="1"> <tr> <td>NAME</td> <td>OPEX Business Machines GmbH</td> </tr> <tr> <td>ADDRESS</td> <td>104 Lower Baggot Street Dublin 2 Republic of Ireland</td> </tr> </table>	NAME	OPEX Business Machines GmbH	ADDRESS	104 Lower Baggot Street Dublin 2 Republic of Ireland														
NAME	OPEX Business Machines GmbH																			
ADDRESS	104 Lower Baggot Street Dublin 2 Republic of Ireland																			
3.0	Description and identification	<table border="1"> <tr> <td>Description</td> <td>Envelope Opener</td> </tr> <tr> <td>Model</td> <td>OM410</td> </tr> <tr> <td>Serial Number</td> <td></td> </tr> <tr> <td>Year Manufactured</td> <td>From 2019</td> </tr> </table>	Description	Envelope Opener	Model	OM410	Serial Number		Year Manufactured	From 2019										
Description	Envelope Opener																			
Model	OM410																			
Serial Number																				
Year Manufactured	From 2019																			
4.0	Directives	<table border="1"> <tr> <td>2014/35/EU</td> <td>Low Voltage Directive</td> </tr> <tr> <td>2014/30/EU</td> <td>Electromagnetic Compatibility Directive</td> </tr> <tr> <td>2011/65/EU</td> <td>RoHS 2 Directive</td> </tr> <tr> <td>2015/863/EU</td> <td>RoHS 3 amendment</td> </tr> </table>	2014/35/EU	Low Voltage Directive	2014/30/EU	Electromagnetic Compatibility Directive	2011/65/EU	RoHS 2 Directive	2015/863/EU	RoHS 3 amendment										
2014/35/EU	Low Voltage Directive																			
2014/30/EU	Electromagnetic Compatibility Directive																			
2011/65/EU	RoHS 2 Directive																			
2015/863/EU	RoHS 3 amendment																			
5.0	Certified Body	<table border="1"> <tr> <td></td> <td>Intertek Testing Services NA, Inc. 70 Codman Hill Rd. Boxborough MA 01719 USA</td> </tr> </table>		Intertek Testing Services NA, Inc. 70 Codman Hill Rd. Boxborough MA 01719 USA																
	Intertek Testing Services NA, Inc. 70 Codman Hill Rd. Boxborough MA 01719 USA																			
6.0	Harmonized Standards used	<table border="1"> <tr> <td>IEC 62368-1:2014Ed.2+C1</td> <td>Audio/video, information and communication technology equipment Part 1: Safety requirements</td> </tr> <tr> <td>IEC 61000-3-2:2014</td> <td>Harmonics</td> </tr> <tr> <td>IEC 61000-3-3:2013</td> <td>Flicker</td> </tr> <tr> <td>IEC 61000-4-2:2008</td> <td>Electro-Static Discharge Immunity Test</td> </tr> <tr> <td>IEC 61000-4-3:2006, IEC 61000-4-3:2006/AMD1:2007 IEC 610004-3:2006/AMD2:2010</td> <td>Radiated, Radio-Frequency, Electromagnetic Immunity</td> </tr> <tr> <td>IEC 61000-4-4:2012</td> <td>Electrical Fast Transient/Burst Immunity Test</td> </tr> <tr> <td>IEC 61000-4-5:2014</td> <td>Immunity to Surges</td> </tr> <tr> <td>IEC 61000-4-6:2013</td> <td>Conducted, Radio-Frequency, Electromagnetic Immunity Test</td> </tr> <tr> <td>IEC 61000-4-11:2004</td> <td>Voltage Dips/Interruptions Immunity Test</td> </tr> </table>	IEC 62368-1:2014Ed.2+C1	Audio/video, information and communication technology equipment Part 1: Safety requirements	IEC 61000-3-2:2014	Harmonics	IEC 61000-3-3:2013	Flicker	IEC 61000-4-2:2008	Electro-Static Discharge Immunity Test	IEC 61000-4-3:2006, IEC 61000-4-3:2006/AMD1:2007 IEC 610004-3:2006/AMD2:2010	Radiated, Radio-Frequency, Electromagnetic Immunity	IEC 61000-4-4:2012	Electrical Fast Transient/Burst Immunity Test	IEC 61000-4-5:2014	Immunity to Surges	IEC 61000-4-6:2013	Conducted, Radio-Frequency, Electromagnetic Immunity Test	IEC 61000-4-11:2004	Voltage Dips/Interruptions Immunity Test
IEC 62368-1:2014Ed.2+C1	Audio/video, information and communication technology equipment Part 1: Safety requirements																			
IEC 61000-3-2:2014	Harmonics																			
IEC 61000-3-3:2013	Flicker																			
IEC 61000-4-2:2008	Electro-Static Discharge Immunity Test																			
IEC 61000-4-3:2006, IEC 61000-4-3:2006/AMD1:2007 IEC 610004-3:2006/AMD2:2010	Radiated, Radio-Frequency, Electromagnetic Immunity																			
IEC 61000-4-4:2012	Electrical Fast Transient/Burst Immunity Test																			
IEC 61000-4-5:2014	Immunity to Surges																			
IEC 61000-4-6:2013	Conducted, Radio-Frequency, Electromagnetic Immunity Test																			
IEC 61000-4-11:2004	Voltage Dips/Interruptions Immunity Test																			
7.0	Technical Standards used	<table border="1"> <tr> <td>UL 62368-1:2014 Ed.2</td> <td>Audio/Video, Information And Communication Technology Equipment - Part 1: Safety Requirements</td> </tr> <tr> <td>CSA C22.2#62368-1:2014 Ed.2</td> <td>Audio/Video, Information And Communication Technology Equipment - Part 1: Safety Requirements</td> </tr> <tr> <td>CISPR 32 Ed 2.0:2015</td> <td>Radiated Emissions, AC Mains Conducted Emissions Electromagnetic Compatibility Of Multimedia Equipment - Emission Requirements</td> </tr> <tr> <td>FCC 47CFR PT 15 Sub Part B: April 16, 2019</td> <td>Radiated Emissions, AC Mains Conducted Emissions Unintentional Radiator</td> </tr> <tr> <td>ISO 7779 Issued:1999/08/01</td> <td>Acoustics - Measurement of Airborne Noise Emitted by Information Technology and Telecommunications Equipment-Second Edition; Amendment 1: 3/01/2003</td> </tr> </table>	UL 62368-1:2014 Ed.2	Audio/Video, Information And Communication Technology Equipment - Part 1: Safety Requirements	CSA C22.2#62368-1:2014 Ed.2	Audio/Video, Information And Communication Technology Equipment - Part 1: Safety Requirements	CISPR 32 Ed 2.0:2015	Radiated Emissions, AC Mains Conducted Emissions Electromagnetic Compatibility Of Multimedia Equipment - Emission Requirements	FCC 47CFR PT 15 Sub Part B: April 16, 2019	Radiated Emissions, AC Mains Conducted Emissions Unintentional Radiator	ISO 7779 Issued:1999/08/01	Acoustics - Measurement of Airborne Noise Emitted by Information Technology and Telecommunications Equipment-Second Edition; Amendment 1: 3/01/2003								
UL 62368-1:2014 Ed.2	Audio/Video, Information And Communication Technology Equipment - Part 1: Safety Requirements																			
CSA C22.2#62368-1:2014 Ed.2	Audio/Video, Information And Communication Technology Equipment - Part 1: Safety Requirements																			
CISPR 32 Ed 2.0:2015	Radiated Emissions, AC Mains Conducted Emissions Electromagnetic Compatibility Of Multimedia Equipment - Emission Requirements																			
FCC 47CFR PT 15 Sub Part B: April 16, 2019	Radiated Emissions, AC Mains Conducted Emissions Unintentional Radiator																			
ISO 7779 Issued:1999/08/01	Acoustics - Measurement of Airborne Noise Emitted by Information Technology and Telecommunications Equipment-Second Edition; Amendment 1: 3/01/2003																			
8.0	Approval	I, the undersigned, hereby declare that the equipment specified above conforms to the above Directive(s) and Standard(s). <table border="1"> <tr> <td>Place of issue</td> <td>Moorestown, NJ, USA</td> </tr> <tr> <td>Date of issue</td> <td>Apr 24, 2019</td> </tr> <tr> <td>Authorized</td> <td>Scott Maurer, </td> </tr> <tr> <td>Title</td> <td>President, International Division</td> </tr> </table>	Place of issue	Moorestown, NJ, USA	Date of issue	Apr 24, 2019	Authorized	Scott Maurer, 	Title	President, International Division										
Place of issue	Moorestown, NJ, USA																			
Date of issue	Apr 24, 2019																			
Authorized	Scott Maurer, 																			
Title	President, International Division																			
Drawing: 92801xx-DoC-IR		Revision: 0.1																		

## 0.2.5. EU Declaration of Conformity Switzerland: SW

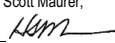
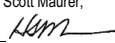
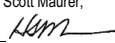
		<b>EU Declaration of Conformity</b> <b>OM410</b>																		
This declaration of conformity is issued under the sole responsibility of the manufacturer.																				
1.0	Manufacturer	<table border="1"> <tr> <td>NAME</td> <td>OPEX Corporation</td> </tr> <tr> <td>ADDRESS</td> <td>835 Lancer Drive, Moorestown, NJ 08057, USA</td> </tr> </table>	NAME	OPEX Corporation	ADDRESS	835 Lancer Drive, Moorestown, NJ 08057, USA														
NAME	OPEX Corporation																			
ADDRESS	835 Lancer Drive, Moorestown, NJ 08057, USA																			
2.0	Technical File	Technical documentation is compiled in accordance with Part B of Annex VII of the machinery directive. This documentation is available on a reasoned request by appropriate national authority to our authorized representative:																		
		<table border="1"> <tr> <td>NAME</td> <td>OPEX Business Machines GmbH</td> </tr> <tr> <td>ADDRESS</td> <td>Pilatusstrasse 41 6003 Luzern Switzerland</td> </tr> </table>	NAME	OPEX Business Machines GmbH	ADDRESS	Pilatusstrasse 41 6003 Luzern Switzerland														
NAME	OPEX Business Machines GmbH																			
ADDRESS	Pilatusstrasse 41 6003 Luzern Switzerland																			
3.0	Description and identification	<table border="1"> <tr> <td>Description</td> <td>Envelope Opener</td> </tr> <tr> <td>Model</td> <td>OM410</td> </tr> <tr> <td>Serial Number</td> <td></td> </tr> <tr> <td>Year Manufactured</td> <td>From 2019</td> </tr> </table>	Description	Envelope Opener	Model	OM410	Serial Number		Year Manufactured	From 2019										
Description	Envelope Opener																			
Model	OM410																			
Serial Number																				
Year Manufactured	From 2019																			
4.0	Directives	<table border="1"> <tr> <td>2014/35/EU</td> <td>Low Voltage Directive</td> </tr> <tr> <td>2014/30/EU</td> <td>Electromagnetic Compatibility Directive</td> </tr> <tr> <td>2011/65/EU</td> <td>RoHS 2 Directive</td> </tr> <tr> <td>2015/863/EU</td> <td>RoHS 3 amendment</td> </tr> </table>	2014/35/EU	Low Voltage Directive	2014/30/EU	Electromagnetic Compatibility Directive	2011/65/EU	RoHS 2 Directive	2015/863/EU	RoHS 3 amendment										
2014/35/EU	Low Voltage Directive																			
2014/30/EU	Electromagnetic Compatibility Directive																			
2011/65/EU	RoHS 2 Directive																			
2015/863/EU	RoHS 3 amendment																			
5.0	Certified Body	<table border="1"> <tr> <td></td> <td>Intertek Testing Services NA, Inc. 70 Codman Hill Rd. Boxborough MA 01719 USA</td> </tr> </table>		Intertek Testing Services NA, Inc. 70 Codman Hill Rd. Boxborough MA 01719 USA																
	Intertek Testing Services NA, Inc. 70 Codman Hill Rd. Boxborough MA 01719 USA																			
6.0	Harmonized Standards used	<table border="1"> <tr> <td>IEC 62368-1:2014Ed.2+C1</td> <td>Audio/video, information and communication technology equipment Part 1: Safety requirements</td> </tr> <tr> <td>IEC 61000-3-2:2014</td> <td>Harmonics</td> </tr> <tr> <td>IEC 61000-3-3:2013</td> <td>Flicker</td> </tr> <tr> <td>IEC 61000-4-2:2008</td> <td>Electro-Static Discharge Immunity Test</td> </tr> <tr> <td>IEC 61000-4-3:2006, IEC 61000-4-3:2006/AMD1:2007 IEC 610004-3:2006/AMD2:2010</td> <td>Radiated, Radio-Frequency, Electromagnetic Immunity</td> </tr> <tr> <td>IEC 61000-4-4:2012</td> <td>Electrical Fast Transient/Burst Immunity Test</td> </tr> <tr> <td>IEC 61000-4-5:2014</td> <td>Immunity to Surges</td> </tr> <tr> <td>IEC 61000-4-6:2013</td> <td>Conducted, Radio-Frequency, Electromagnetic Immunity Test</td> </tr> <tr> <td>IEC 61000-4-11:2004</td> <td>Voltage Dips/Interruptions Immunity Test</td> </tr> </table>	IEC 62368-1:2014Ed.2+C1	Audio/video, information and communication technology equipment Part 1: Safety requirements	IEC 61000-3-2:2014	Harmonics	IEC 61000-3-3:2013	Flicker	IEC 61000-4-2:2008	Electro-Static Discharge Immunity Test	IEC 61000-4-3:2006, IEC 61000-4-3:2006/AMD1:2007 IEC 610004-3:2006/AMD2:2010	Radiated, Radio-Frequency, Electromagnetic Immunity	IEC 61000-4-4:2012	Electrical Fast Transient/Burst Immunity Test	IEC 61000-4-5:2014	Immunity to Surges	IEC 61000-4-6:2013	Conducted, Radio-Frequency, Electromagnetic Immunity Test	IEC 61000-4-11:2004	Voltage Dips/Interruptions Immunity Test
IEC 62368-1:2014Ed.2+C1	Audio/video, information and communication technology equipment Part 1: Safety requirements																			
IEC 61000-3-2:2014	Harmonics																			
IEC 61000-3-3:2013	Flicker																			
IEC 61000-4-2:2008	Electro-Static Discharge Immunity Test																			
IEC 61000-4-3:2006, IEC 61000-4-3:2006/AMD1:2007 IEC 610004-3:2006/AMD2:2010	Radiated, Radio-Frequency, Electromagnetic Immunity																			
IEC 61000-4-4:2012	Electrical Fast Transient/Burst Immunity Test																			
IEC 61000-4-5:2014	Immunity to Surges																			
IEC 61000-4-6:2013	Conducted, Radio-Frequency, Electromagnetic Immunity Test																			
IEC 61000-4-11:2004	Voltage Dips/Interruptions Immunity Test																			
7.0	Technical Standards used	<table border="1"> <tr> <td>UL 62368-1:2014 Ed.2</td> <td>Audio/Video, Information And Communication Technology Equipment - Part 1: Safety Requirements</td> </tr> <tr> <td>CSA C22.2#62368-1:2014 Ed.2</td> <td>Audio/Video, Information And Communication Technology Equipment - Part 1: Safety Requirements</td> </tr> <tr> <td>CISPR 32 Ed 2.0:2015</td> <td>Radiated Emissions, AC Mains Conducted Emissions Electromagnetic Compatibility Of Multimedia Equipment - Emission Requirements</td> </tr> <tr> <td>FCC 47CFR PT 15 Sub Part B: April 16, 2019</td> <td>Radiated Emissions, AC Mains Conducted Emissions Unintentional Radiator</td> </tr> <tr> <td>ISO 7779 Issued:1999/08/01</td> <td>Acoustics - Measurement of Airborne Noise Emitted by Information Technology and Telecommunications Equipment-Second Edition; Amendment 1: 3/01/2003</td> </tr> </table>	UL 62368-1:2014 Ed.2	Audio/Video, Information And Communication Technology Equipment - Part 1: Safety Requirements	CSA C22.2#62368-1:2014 Ed.2	Audio/Video, Information And Communication Technology Equipment - Part 1: Safety Requirements	CISPR 32 Ed 2.0:2015	Radiated Emissions, AC Mains Conducted Emissions Electromagnetic Compatibility Of Multimedia Equipment - Emission Requirements	FCC 47CFR PT 15 Sub Part B: April 16, 2019	Radiated Emissions, AC Mains Conducted Emissions Unintentional Radiator	ISO 7779 Issued:1999/08/01	Acoustics - Measurement of Airborne Noise Emitted by Information Technology and Telecommunications Equipment-Second Edition; Amendment 1: 3/01/2003								
UL 62368-1:2014 Ed.2	Audio/Video, Information And Communication Technology Equipment - Part 1: Safety Requirements																			
CSA C22.2#62368-1:2014 Ed.2	Audio/Video, Information And Communication Technology Equipment - Part 1: Safety Requirements																			
CISPR 32 Ed 2.0:2015	Radiated Emissions, AC Mains Conducted Emissions Electromagnetic Compatibility Of Multimedia Equipment - Emission Requirements																			
FCC 47CFR PT 15 Sub Part B: April 16, 2019	Radiated Emissions, AC Mains Conducted Emissions Unintentional Radiator																			
ISO 7779 Issued:1999/08/01	Acoustics - Measurement of Airborne Noise Emitted by Information Technology and Telecommunications Equipment-Second Edition; Amendment 1: 3/01/2003																			
8.0	Approval	I, the undersigned, hereby declare that the equipment specified above conforms to the above Directive(s) and Standard(s).																		
		<table border="1"> <tr> <td>Place of issue</td> <td>Moorestown, NJ, USA</td> </tr> <tr> <td>Date of issue</td> <td>Apr 24, 2019</td> </tr> <tr> <td>Authorized</td> <td>Scott Maurer, </td> </tr> <tr> <td>Title</td> <td>President, International Division</td> </tr> </table>	Place of issue	Moorestown, NJ, USA	Date of issue	Apr 24, 2019	Authorized	Scott Maurer, 	Title	President, International Division										
Place of issue	Moorestown, NJ, USA																			
Date of issue	Apr 24, 2019																			
Authorized	Scott Maurer, 																			
Title	President, International Division																			
Drawing: 92801xx-DoC-SW		Revision: 0.1																		

# 0.2.6. EU Declaration of Conformity United Kingdom: UK

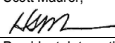
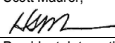
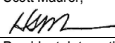
		<b>EU Declaration of Conformity</b> <b>OM410</b> This declaration of conformity is issued under the sole responsibility of the manufacturer.																		
1.0	<b>Manufacturer</b>	<table border="1"> <tr> <td>NAME</td> <td>OPEX Corporation</td> </tr> <tr> <td>ADDRESS</td> <td>835 Lancer Drive, Moorestown, NJ 08057, USA</td> </tr> </table>	NAME	OPEX Corporation	ADDRESS	835 Lancer Drive, Moorestown, NJ 08057, USA														
NAME	OPEX Corporation																			
ADDRESS	835 Lancer Drive, Moorestown, NJ 08057, USA																			
2.0	<b>Technical File</b>	Technical documentation is compiled in accordance with Part B of Annex VII of the machinery directive. This documentation is available on a reasoned request by appropriate national authority to our authorized representative: <table border="1"> <tr> <td>NAME</td> <td>OPEX Business Machines GmbH</td> </tr> <tr> <td>ADDRESS</td> <td>29/32 Queensbrook Bolton Technology Exchange Spa Road Bolton, BL1 4AY United Kingdom</td> </tr> </table>	NAME	OPEX Business Machines GmbH	ADDRESS	29/32 Queensbrook Bolton Technology Exchange Spa Road Bolton, BL1 4AY United Kingdom														
NAME	OPEX Business Machines GmbH																			
ADDRESS	29/32 Queensbrook Bolton Technology Exchange Spa Road Bolton, BL1 4AY United Kingdom																			
3.0	<b>Description and identification</b>	<table border="1"> <tr> <td>Description</td> <td>Envelope Opener</td> </tr> <tr> <td>Model</td> <td>OM410</td> </tr> <tr> <td>Serial Number</td> <td></td> </tr> <tr> <td>Year Manufactured</td> <td>From 2019</td> </tr> </table>	Description	Envelope Opener	Model	OM410	Serial Number		Year Manufactured	From 2019										
Description	Envelope Opener																			
Model	OM410																			
Serial Number																				
Year Manufactured	From 2019																			
4.0	<b>Directives</b>	<table border="1"> <tr> <td>2014/35/EU</td> <td>Low Voltage Directive</td> </tr> <tr> <td>2014/30/EU</td> <td>Electromagnetic Compatibility Directive</td> </tr> <tr> <td>2011/65/EU</td> <td>RoHS 2 Directive</td> </tr> <tr> <td>2015/863/EU</td> <td>RoHS 3 amendment</td> </tr> </table>	2014/35/EU	Low Voltage Directive	2014/30/EU	Electromagnetic Compatibility Directive	2011/65/EU	RoHS 2 Directive	2015/863/EU	RoHS 3 amendment										
2014/35/EU	Low Voltage Directive																			
2014/30/EU	Electromagnetic Compatibility Directive																			
2011/65/EU	RoHS 2 Directive																			
2015/863/EU	RoHS 3 amendment																			
5.0	<b>Certified Body</b>	<table border="1"> <tr> <td></td> <td>Intertek Testing Services NA, Inc. 70 Codman Hill Rd. Boxborough MA 01719 USA</td> </tr> </table>		Intertek Testing Services NA, Inc. 70 Codman Hill Rd. Boxborough MA 01719 USA																
	Intertek Testing Services NA, Inc. 70 Codman Hill Rd. Boxborough MA 01719 USA																			
6.0	<b>Harmonized Standards used</b>	<table border="1"> <tr> <td>IEC 62368-1:2014Ed.2+C1</td> <td>Audio/video, information and communication technology equipment Part 1: Safety requirements</td> </tr> <tr> <td>IEC 61000-3-2:2014</td> <td>Harmonics</td> </tr> <tr> <td>IEC 61000-3-3:2013</td> <td>Flicker</td> </tr> <tr> <td>IEC 61000-4-2:2008</td> <td>Electro-Static Discharge Immunity Test</td> </tr> <tr> <td>IEC 61000-4-3:2006, IEC 61000-4-3:2006/AMD1:2007 IEC 610004-3:2006/AMD2:2010</td> <td>Radiated, Radio-Frequency, Electromagnetic Immunity</td> </tr> <tr> <td>IEC 61000-4-4:2012</td> <td>Electrical Fast Transient/Burst Immunity Test</td> </tr> <tr> <td>IEC 61000-4-5:2014</td> <td>Immunity to Surges</td> </tr> <tr> <td>IEC 61000-4-6:2013</td> <td>Conducted, Radio-Frequency, Electromagnetic Immunity Test</td> </tr> <tr> <td>IEC 61000-4-11:2004</td> <td>Voltage Dips/Interruptions Immunity Test</td> </tr> </table>	IEC 62368-1:2014Ed.2+C1	Audio/video, information and communication technology equipment Part 1: Safety requirements	IEC 61000-3-2:2014	Harmonics	IEC 61000-3-3:2013	Flicker	IEC 61000-4-2:2008	Electro-Static Discharge Immunity Test	IEC 61000-4-3:2006, IEC 61000-4-3:2006/AMD1:2007 IEC 610004-3:2006/AMD2:2010	Radiated, Radio-Frequency, Electromagnetic Immunity	IEC 61000-4-4:2012	Electrical Fast Transient/Burst Immunity Test	IEC 61000-4-5:2014	Immunity to Surges	IEC 61000-4-6:2013	Conducted, Radio-Frequency, Electromagnetic Immunity Test	IEC 61000-4-11:2004	Voltage Dips/Interruptions Immunity Test
IEC 62368-1:2014Ed.2+C1	Audio/video, information and communication technology equipment Part 1: Safety requirements																			
IEC 61000-3-2:2014	Harmonics																			
IEC 61000-3-3:2013	Flicker																			
IEC 61000-4-2:2008	Electro-Static Discharge Immunity Test																			
IEC 61000-4-3:2006, IEC 61000-4-3:2006/AMD1:2007 IEC 610004-3:2006/AMD2:2010	Radiated, Radio-Frequency, Electromagnetic Immunity																			
IEC 61000-4-4:2012	Electrical Fast Transient/Burst Immunity Test																			
IEC 61000-4-5:2014	Immunity to Surges																			
IEC 61000-4-6:2013	Conducted, Radio-Frequency, Electromagnetic Immunity Test																			
IEC 61000-4-11:2004	Voltage Dips/Interruptions Immunity Test																			
7.0	<b>Technical Standards used</b>	<table border="1"> <tr> <td>UL 62368-1:2014 Ed.2</td> <td>Audio/Video, Information And Communication Technology Equipment - Part 1: Safety Requirements</td> </tr> <tr> <td>CSA C22.2#62368-1:2014 Ed.2</td> <td>Audio/Video, Information And Communication Technology Equipment - Part 1: Safety Requirements</td> </tr> <tr> <td>CISPR 32 Ed 2.0:2015</td> <td>Radiated Emissions, AC Mains Conducted Emissions Electromagnetic Compatibility Of Multimedia Equipment - Emission Requirements</td> </tr> <tr> <td>FCC 47CFR PT 15 Sub Part B: April 16, 2019</td> <td>Radiated Emissions, AC Mains Conducted Emissions Unintentional Radiator</td> </tr> <tr> <td>ISO 7779 Issued:1999/08/01</td> <td>Acoustics - Measurement of Airborne Noise Emitted by Information Technology and Telecommunications Equipment-Second Edition; Amendment 1: 3/01/2003</td> </tr> </table>	UL 62368-1:2014 Ed.2	Audio/Video, Information And Communication Technology Equipment - Part 1: Safety Requirements	CSA C22.2#62368-1:2014 Ed.2	Audio/Video, Information And Communication Technology Equipment - Part 1: Safety Requirements	CISPR 32 Ed 2.0:2015	Radiated Emissions, AC Mains Conducted Emissions Electromagnetic Compatibility Of Multimedia Equipment - Emission Requirements	FCC 47CFR PT 15 Sub Part B: April 16, 2019	Radiated Emissions, AC Mains Conducted Emissions Unintentional Radiator	ISO 7779 Issued:1999/08/01	Acoustics - Measurement of Airborne Noise Emitted by Information Technology and Telecommunications Equipment-Second Edition; Amendment 1: 3/01/2003								
UL 62368-1:2014 Ed.2	Audio/Video, Information And Communication Technology Equipment - Part 1: Safety Requirements																			
CSA C22.2#62368-1:2014 Ed.2	Audio/Video, Information And Communication Technology Equipment - Part 1: Safety Requirements																			
CISPR 32 Ed 2.0:2015	Radiated Emissions, AC Mains Conducted Emissions Electromagnetic Compatibility Of Multimedia Equipment - Emission Requirements																			
FCC 47CFR PT 15 Sub Part B: April 16, 2019	Radiated Emissions, AC Mains Conducted Emissions Unintentional Radiator																			
ISO 7779 Issued:1999/08/01	Acoustics - Measurement of Airborne Noise Emitted by Information Technology and Telecommunications Equipment-Second Edition; Amendment 1: 3/01/2003																			
8.0	<b>Approval</b>	I, the undersigned, hereby declare that the equipment specified above conforms to the above Directive(s) and Standard(s). <table border="1"> <tr> <td>Place of issue</td> <td>Moorestown, NJ, USA</td> </tr> <tr> <td>Date of issue</td> <td>Apr 24, 2019</td> </tr> <tr> <td>Authorized</td> <td>Scott Maurer, </td> </tr> <tr> <td>Title</td> <td>President, International Division</td> </tr> </table>	Place of issue	Moorestown, NJ, USA	Date of issue	Apr 24, 2019	Authorized	Scott Maurer, 	Title	President, International Division										
Place of issue	Moorestown, NJ, USA																			
Date of issue	Apr 24, 2019																			
Authorized	Scott Maurer, 																			
Title	President, International Division																			
Drawing: 92801xx-DoC-UK		Revision: 0.1																		

---

---

## 0.3. Document History

---

---

Doc Rev	Date	Changes (click blue text to go to that page)
19-01	Apr 30, 2019	Initial release CE compliant

---

---

# Table of Contents

---

---

0.1. Contacting OPEX .....	2
0.2. EU Declaration of Conformity .....	3
0.2.1. EU Declaration of Conformity Australia: AU .....	3
0.2.2. EU Declaration of Conformity France: FR .....	4
0.2.3. EU Declaration of Conformity Germany: GR .....	5
0.2.4. EU Declaration of Conformity Republic of Ireland: IR .....	6
0.2.5. EU Declaration of Conformity Switzerland: SW .....	7
0.2.6. EU Declaration of Conformity United Kingdom: UK .....	8
0.3. Document History .....	9

## Chapter 1

### Introduction

1.1. About This Manual .....	14
1.1.1. Manual navigation aids .....	14

## Chapter 2

### Safety

2.1. Introduction .....	16
2.1.1. Safety message conventions .....	17
2.2. Safety Guidelines .....	18
2.2.1. Safety guidelines - English translation .....	18
2.2.2. Consignes de Sécurité - traduction française .....	19
2.3. Safety Labels .....	20
2.3.1. Interlock system .....	25
2.4. Ergonomics .....	26
2.5. Personal Protective Equipment .....	26

## Chapter 3

### Overview

3.1. System Overview .....	28
----------------------------	----

3.2. Equipment Model/Serial Number Locations ..... 30

**Chapter 4**  
**Operation**

4.1. Operation ..... 32

- 4.1.1. Machine Controls ..... 32
- 4.1.2. The Run Screen ..... 34

4.2. Operating Instructions ..... 37

- 4.2.1. Order of Operation ..... 37
- 4.2.2. Output Tray Position ..... 42
- 4.2.3. Clearing Jams ..... 43

4.3. Routine Maintenance ..... 44

- 4.3.1. Cleaning the Series 410 Envelopener™ ..... 44
- 4.3.2. Replacing the Print Cartridge ..... 47
- 4.3.3. Cutter Adjustment ..... 49
- 4.3.4. Resetting the circuit breaker ..... 51

4.4. User Replaceable Parts ..... 53

**Chapter 5**  
**Specifications**

5.1. Physical Specifications ..... 60

5.2. Features ..... 60

5.3. Electrical Requirements ..... 61

5.4. Environmental Specifications ..... 61

**Glossary** ..... **63**

G.1. List of Terms ..... 64





# 1. Introduction

1.1. About This Manual .....	14
1.1.1. Manual navigation aids .....	14

---

---

## 1.1. About This Manual

---

---

This manual contains information about the OPEX OMATION® Series 410 Envelopener™ and its operational procedures and safety-related components, including:

- safety information, safety hazards and precautions
- main component identification and function
- system specifications
- minor maintenance and cleaning

This information is intended for use by the main operator of the OMATION® Series 410 Envelopener™. The operator can load envelopes onto the feed hopper, start the machine which will cut open and/or count the envelopes. They can also perform minor maintenance. Read all information thoroughly before attempting to operate or service this equipment.

This manual will be updated to reflect equipment design changes, part number changes, or to correct errors (a table detailing the document revision history can be viewed on [Page 9](#)). Be sure to retain the latest electronic release of the manual for your reference. The latest release can be downloaded in PDF format at [www.opexservice.com](http://www.opexservice.com) (authorized, registered users only).

### 1.1.1. Manual navigation aids

This manual is designed primarily for use on a tablet device. To improve navigation, the manual contains blue underlined links you can click on or tap to go directly to a particular page or web address. In addition, all items in the [“Table of Contents”](#) as well as the bookmarks in the side bar of the PDF file can be clicked or tapped to navigate directly to a particular page. Make sure to use the latest version of Adobe® Acrobat Reader®\* for optimal performance.

\*Adobe and Acrobat Reader are registered trademarks of Adobe Systems Incorporated.

# 2. Safety

<b>2.1. Introduction</b> .....	<b>16</b>
2.1.1. Safety message conventions .....	17
<b>2.2. Safety Guidelines</b> .....	<b>18</b>
2.2.1. Safety guidelines - English translation .....	18
2.2.2. Consignes de Sécurité - traduction française .....	19
<b>2.3. Safety Labels</b> .....	<b>20</b>
2.3.1. Interlock system .....	25
<b>2.4. Ergonomics</b> .....	<b>26</b>
<b>2.5. Personal Protective Equipment</b> .....	<b>26</b>

---

---

## 2.1. Introduction

---

---

The information provided in this chapter is intended to educate you on various safety issues regarding the operation and maintenance of the OPEX equipment described in this manual.

This chapter provides an explanation of the safety conventions used throughout this manual, as well as safety guidelines to be observed when working with this equipment.



### **WARNING**

Read this chapter thoroughly before working with this equipment.

## 2.1.1. Safety message conventions

This manual uses the following conventions to alert you about safety hazards associated with certain procedures and situations. Please be aware of these conventions when reading the manual and operating the equipment:



### **DANGER**

Indicates a hazardous situation that, if not avoided, will result in death or severe injury. The use of this signal word is limited to the most extreme situations.



### **WARNING**

Indicates a hazardous situation that, if not avoided, could result in death or serious injury.



### **CAUTION**

Indicates a hazardous situation that, if not avoided, could result in minor or moderate injury.

### **NOTICE**

Indicates information considered important, but not hazard related (e.g. messages relating to property damage).

---

---

## 2.2. Safety Guidelines

---

---

### 2.2.1. Safety guidelines - English translation

This section provides safety guidelines to be observed when working with this equipment.

**Normal operations** - Only authorized personnel shall start, operate, or interfere with the normal working of the machine. Operator training is required, and training is provided in [page 32](#).

**Keep loose objects away from any exposed, moving parts of the machine** - The moving parts of the OMATION® Series 410 Envelopener™, such as the conveyor, can become jammed and/or damaged by foreign objects. Keep hands, hair, loose clothing and jewelry away from the moving parts.

**Machine design** - Do not modify the design or configuration of the equipment without consulting OPEX or your authorized representative.

**Machine Maintenance** - Machine maintenance, particular operations, and all adjustments, whether mechanical or electrical, shall be carried out by persons authorized to do so in accordance with a safe system of work.

**Do not attempt to clean the machine while it is running** - A cloth (or similar material) should never be used to clean moving parts such as belts or rollers. The use of such material on moving mechanisms can result in damage to the machine or severe personal injury. If a belt, roller, gate or similar part needs to be cleaned, hand-crank the part during cleaning or clean it while stationary.

**Do not use flammable, high pressure, “canned air” to clean dust and debris from the machine.**

**Machine access** - Keep all areas around the machine clear of obstacles.

**Electrical outlet** - The socket-outlet shall be installed near the equipment and shall be easily accessible.

**Keep away from children** - This equipment is not suitable for use in locations where children are likely to be present.

## 2.2.2. Consignes de Sécurité - traduction française

**Opérations normales** - Seul le personnel autorisé doit démarrer, opérer ou interférer avec le fonctionnement normal de la machine. La formation de l'opérateur est requise et la formation est fournie dans "Opération".

### **Gardez les objets lâches à l'écart des parties exposées et mobiles de la machine**

- Les parties mobiles du Sure Sort, telles que le convoyeur, peuvent être bloquées et / ou endommagées par des objets étrangers. Gardez les mains, les cheveux, les vêtements lâches et les bijoux loin des pièces mobiles.

**Conception de la machine** - Ne modifiez pas la conception ou la configuration de l'équipement sans consulter OPEX ou votre représentant autorisé.

**L'entretien des machines** - La maintenance de la machine, les opérations particulières et tous les réglages, qu'ils soient mécaniques ou électriques, doivent être effectués par des personnes autorisées à le faire conformément à un système de travail sûr.

**N'essayez pas de nettoyer la machine pendant son fonctionnement** - Un chiffon (ou un matériau similaire) ne doit jamais être utilisé pour nettoyer les pièces mobiles telles que les courroies ou les rouleaux. L'utilisation d'un tel matériau sur les mécanismes de déplacement peut endommager la machine ou subir des blessures graves. Si une ceinture, un rouleau, une grille ou une pièce similaire doivent être nettoyés, faire manivellez la pièce pendant le nettoyage ou la nettoyer en stationnaire.

**N'utilisez pas d'air comprimé inflammable, à haute pression pour nettoyer la poussière et les débris de la machine.**

**Accès à la machine** - Gardez toutes les zones autour de la machine sans obstacles.

**Sortie électrique** - La prise doit être installée à proximité de l'équipement et doit être facilement accessible.

**Accès à la machine** - Gardez toutes les zones autour de la machine sans obstacles.

**Tenir à l'écart des enfants** - Cet équipement ne convient pas aux endroits où les enfants sont susceptibles d'être présents.

---

## 2.3. Safety Labels

---

Assorted safety labels appear on the machine in various locations, and are described below. In many cases, there are two different versions of the same label: one for US machines (bilingual), and one for International machines (no text). Though they appear different, the locations of these labels are identical.

**Feeder Warning** -The feeder warning label is found on the front of the machine, above where envelopes are fed (Figure 2-1).

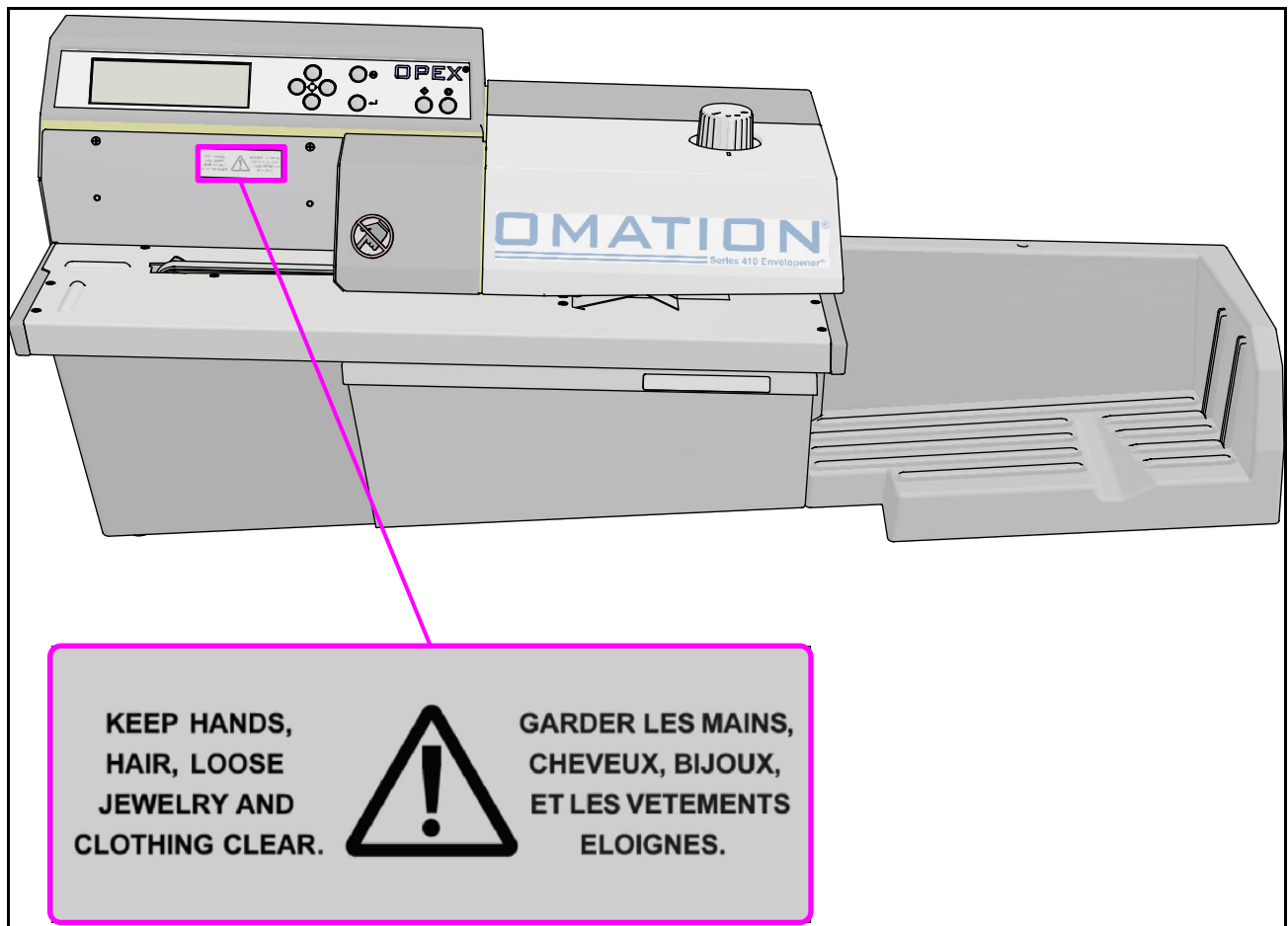

**Figure 2-1: Feeder Warning label**



**Pinch point warnings** - The “keep fingers away from gaps near moving parts” label (1637200) is found at the beginning and end of the feed belt path (Figure 2-2).

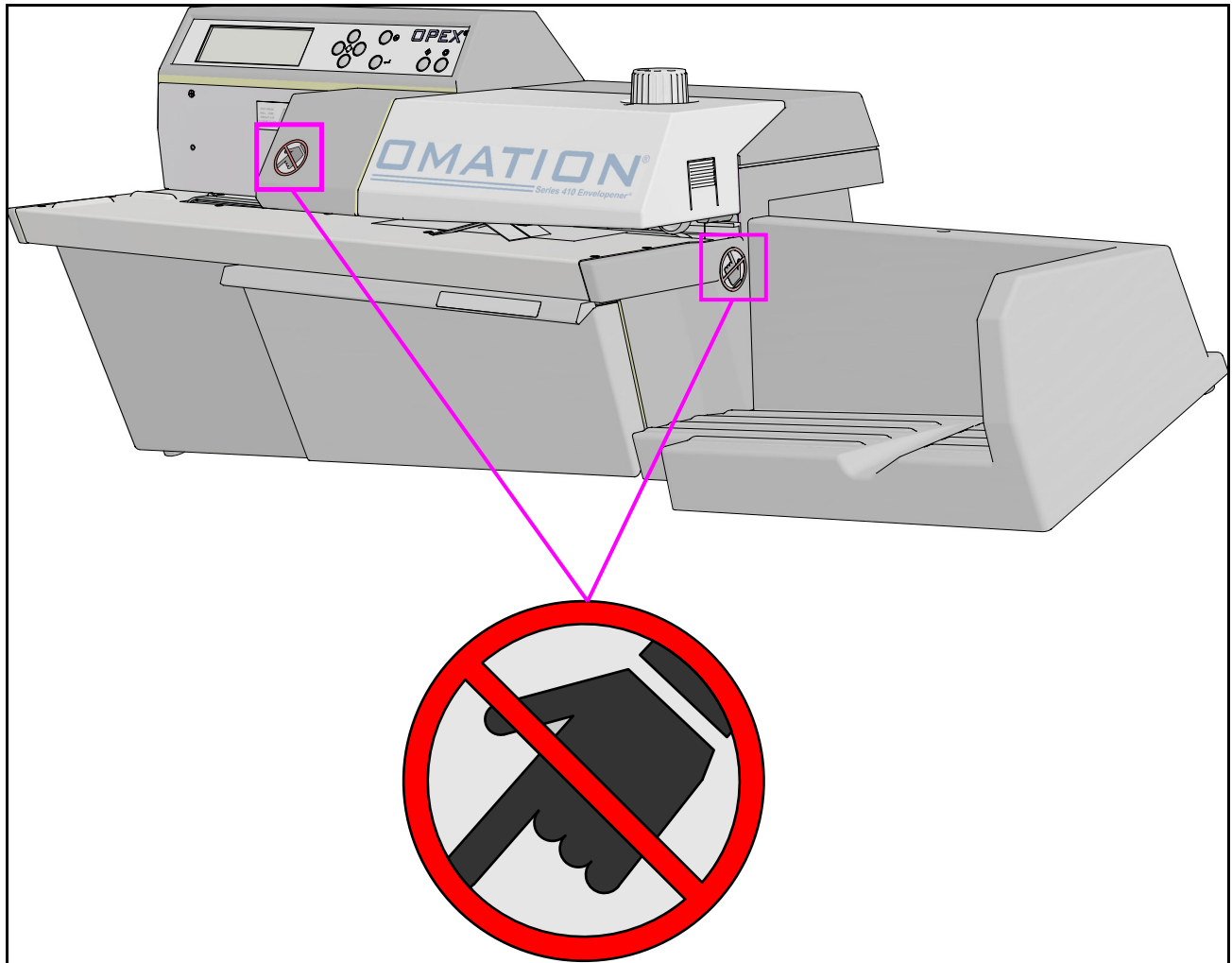

**Figure 2-2: Pinch Point label**

**Disconnect power warning** - The following label (7501900) is found on the rear of the machine (Figure 2-3).

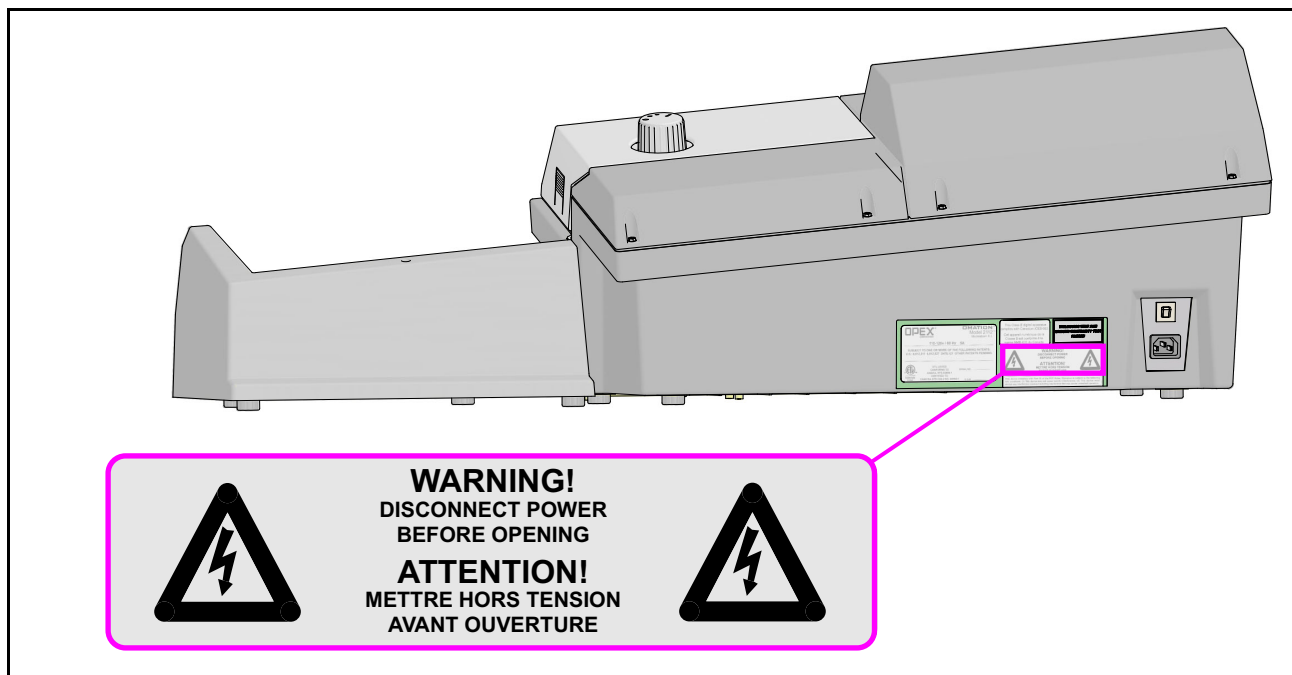

**Figure 2-3: Disconnect Power Before Opening label**

**Dielectric and ground test label** - The following label (P24838-01) is found on the rear of the machine (Figure 2-4).

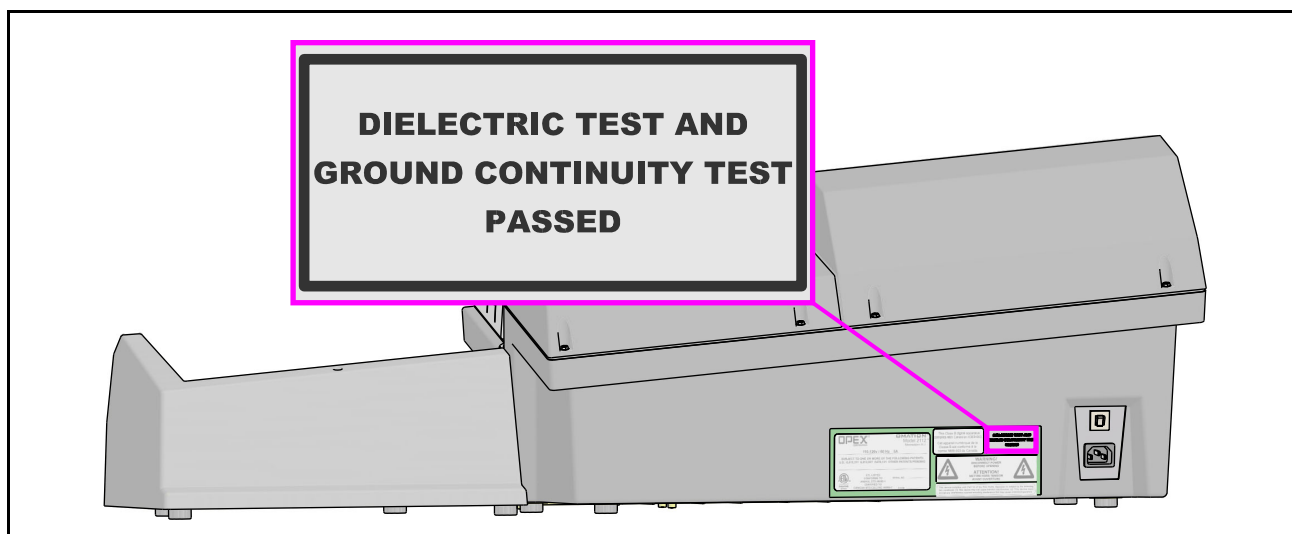

**Figure 2-4: Dielectric and Ground Test label**

**FCC Compliance** - The FCC compliance label (P24839-03) is found on the rear of North American machines only (Figure 2-5).

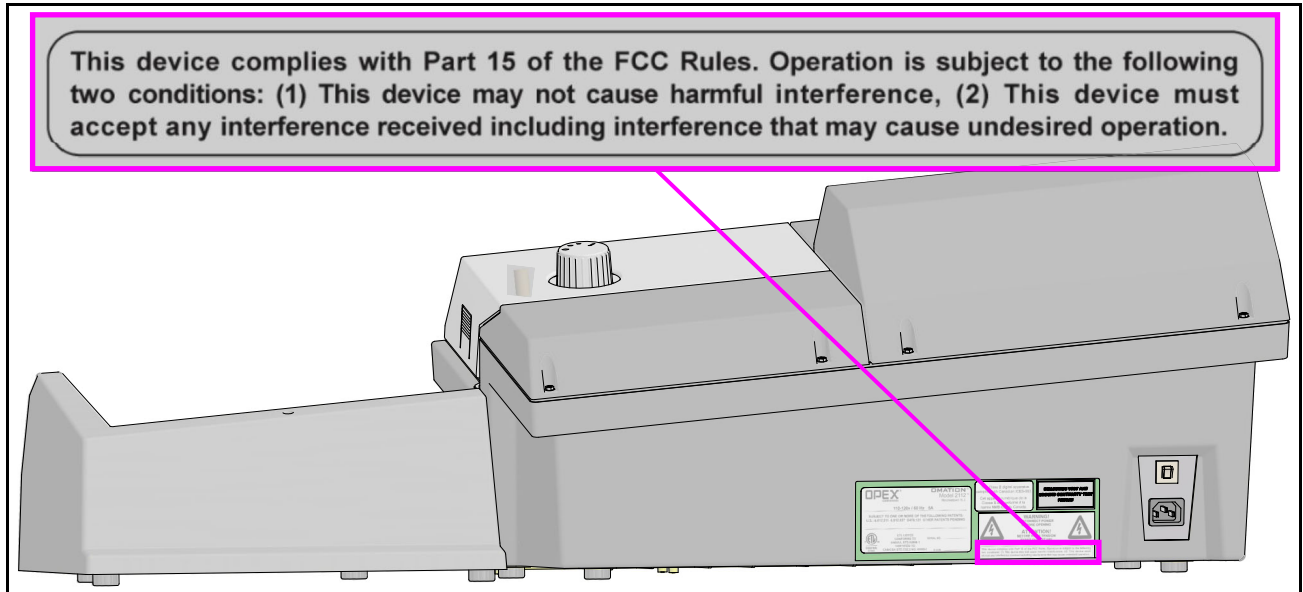

**Figure 2-5: FCC Compliance Label**

**Model and Serial** - The machine's model, serial number, and related info is provided on this label (8176900) on the back (Figure 2-6).

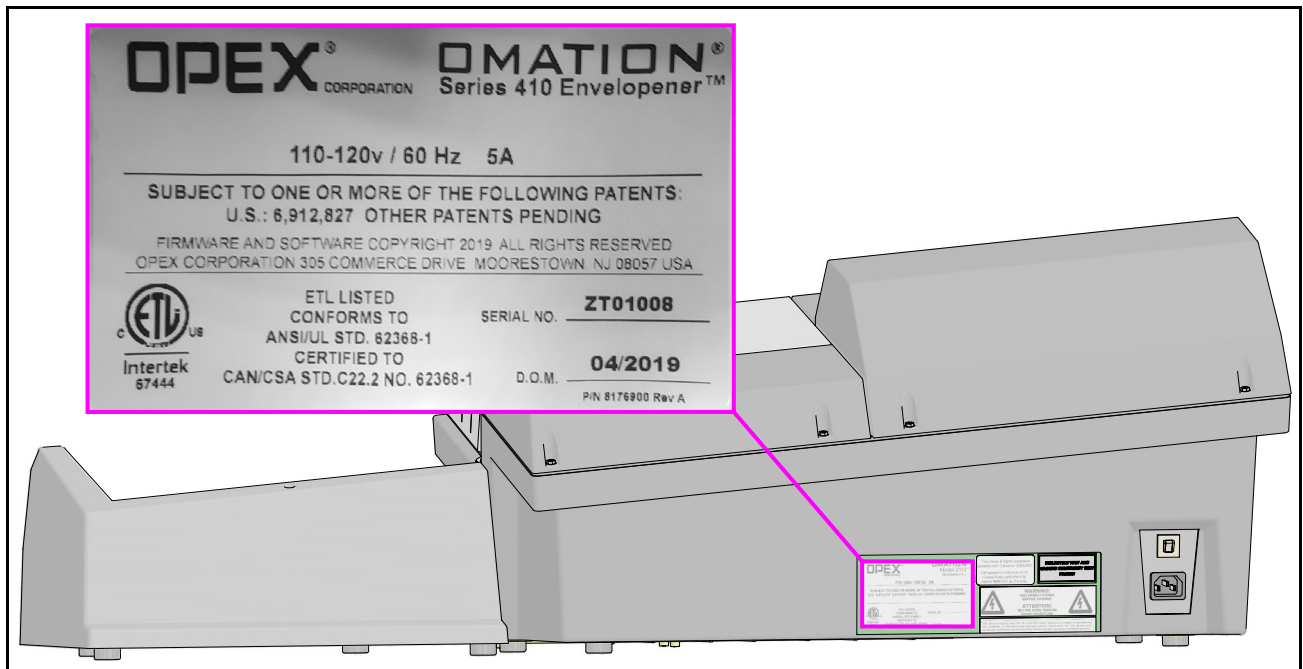

**Figure 2-6: Model / Serial Label**

**ICES-003 label** - The compliance label (7611000) for Canadian ICES-003 is on the back of North American machines only (Figure 2-7).

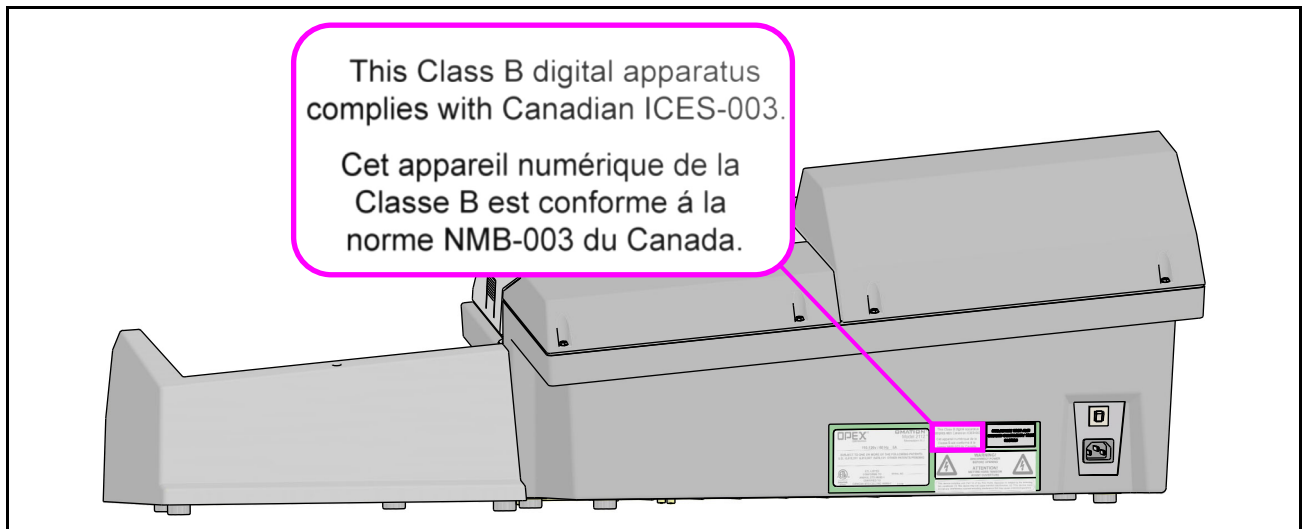

**Figure 2-7: ICES-003 Label**

**Chip Bin Label** - The following label (9280100) is located on the handle of the Chip Bin (Figure 2-8).

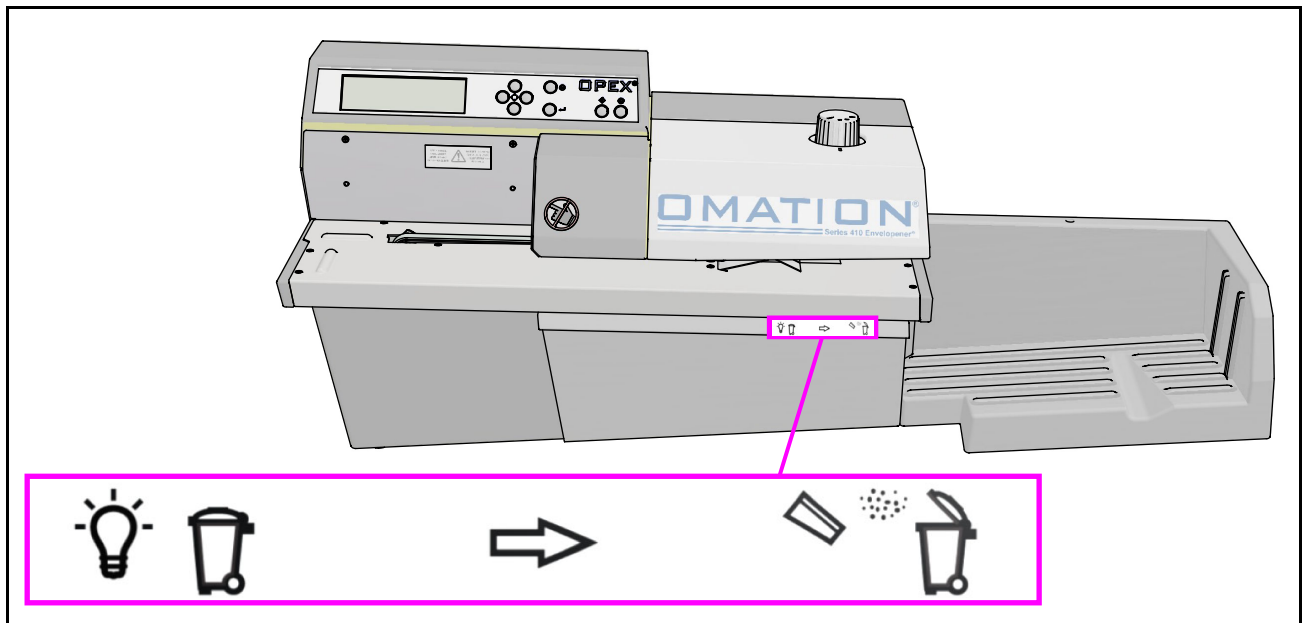

**Figure 2-8: Chip Bin Label**

## 2.3.1. Interlock system

1. The interlock system will stop all the motors in the machine whenever the nip arm cover (Figure 2-9) or chip bin tray (Figure 2-10) is removed.



**Figure 2-9: Top cover removal interlock triggering**



**Figure 2-10: Bin tray removal interlock triggering**

---

---

## 2.4. Ergonomics

---

---

As in any occupation that requires you to perform the same motion repeatedly during the course of your work, it is important to consider how you perform your task. Listed below are some guidelines to help you minimize the risk of physical discomfort and injury while operating the equipment.

**NOTICE**

Always observe the following guidelines when operating the OMATION® Series 410 Envelopener™.

**When at the main operator station:**

- Maintain an upright body posture.
- Occasionally change the angle of your posture for greater comfort.
- Avoid operating the machine for longer than a single 10-hour shift. If possible, stretch between breaks.

---

---

## 2.5. Personal Protective Equipment

---

---

Personal protective equipment (PPE) refers to wearable safety items such as gloves, safety glasses, hard hats, and high-visibility vests. Before starting, find out what PPE is required per local law and the specific job site.

# 3. Overview

3.1. System Overview .....	28
3.2. Equipment Model/Serial Number Locations.....	30



## 3.1. System Overview

The OMATION® Series 410 Envelopener™ is a high-speed envelope opener that can open, count, and print on envelopes.

Features include:

- Advanced self-adjusting feeder for efficient mixed mail opening
- Milling cutter that can remove as little as 0.010" of a chip
- Printer which can print date, time, and/or a sequence number
- Enhanced chip management/chip capacity
- Three depths of cut and a no-cut option
- Large variety of mail types

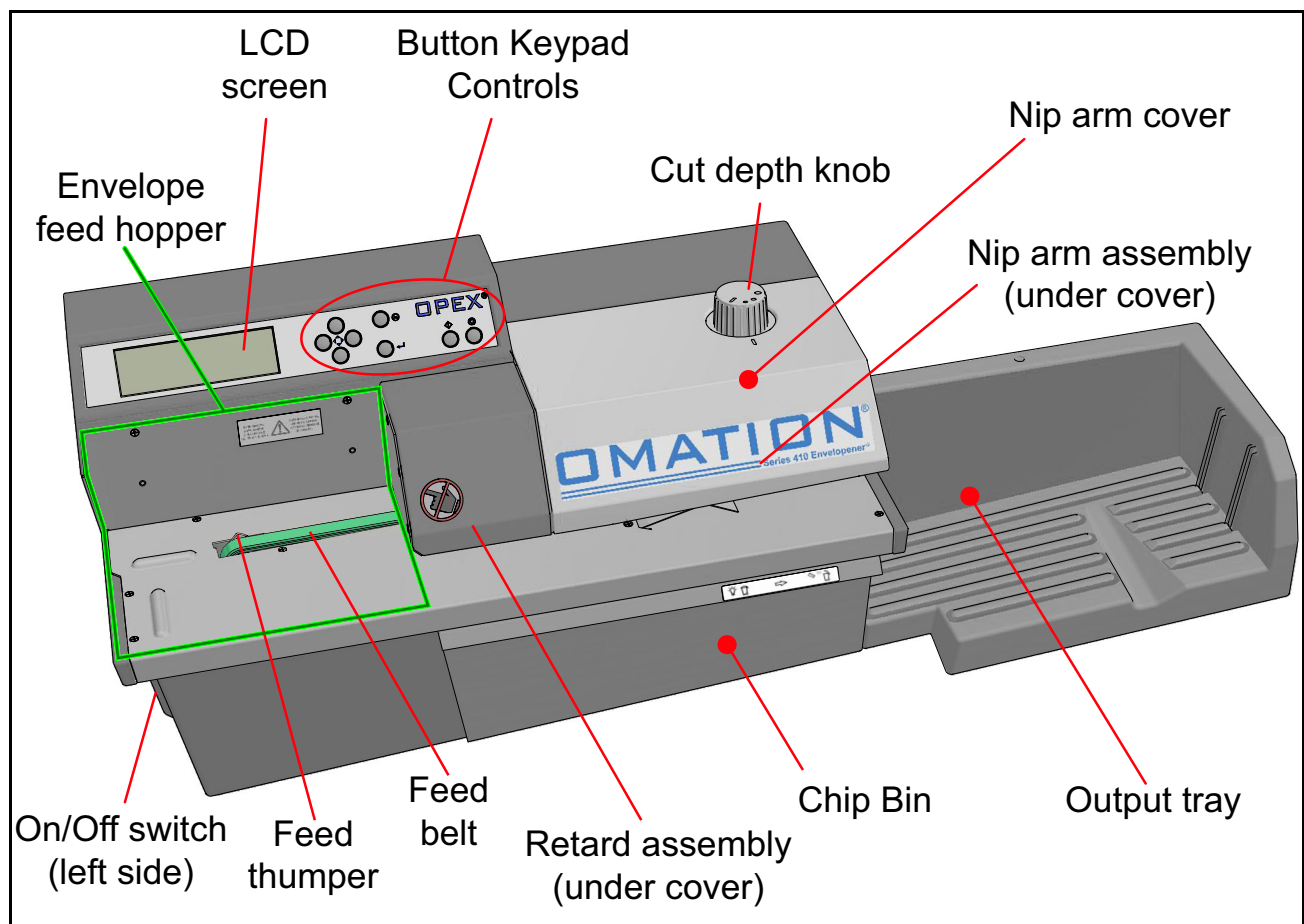

**Figure 3-1: Main Components Front View**



The Series 410 button controls are located on the keypad to the right of the LCD screen as indicated in Figure 3-2. This keypad is described in further detail in ["Keypad Button Functionality" on page 32](#).

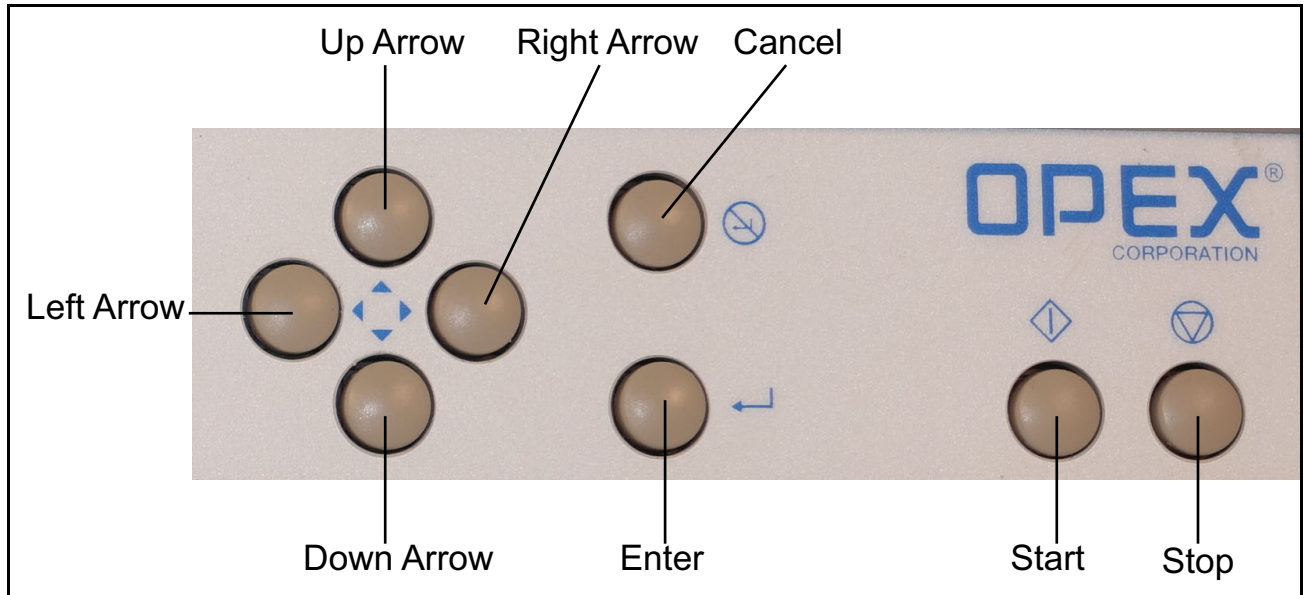

**Figure 3-2: Series 410 keypad button names**

Please take time to familiarize yourself with the various parts of the machine, which are referred to throughout this manual in [Figure 3-1 on page 28](#).



**WARNING**

Read and follow all information in [Chapter 2: "Safety"](#) before attempting to operate this equipment.

## 3.2. Equipment Model/Serial Number Locations

Before contacting OPEX Technical Support, locate the Model/Serial label on your machine so that you can provide the assisting technician with your Reference Serial Number (Figure 3-3). See [“Contacting OPEX” on page 2](#) for contact information.

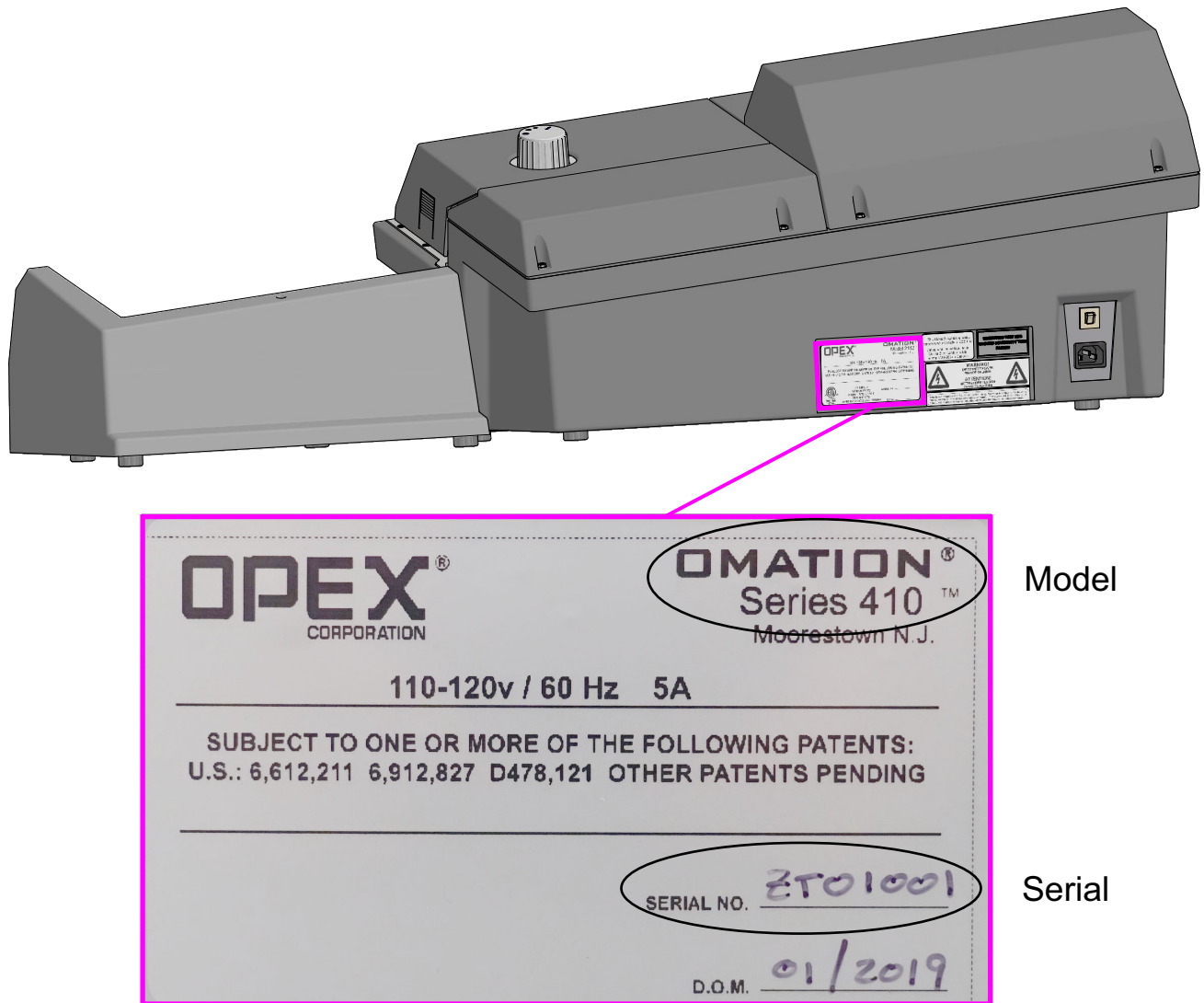

**Figure 3-3: Model/Serial label**

# 4. Operation

<b>4.1. Operation</b> .....	<b>32</b>
4.1.1. Machine Controls .....	32
4.1.2. The Run Screen .....	34
<b>4.2. Operating Instructions</b> .....	<b>37</b>
4.2.1. Order of Operation .....	37
4.2.2. Output Tray Position .....	42
4.2.3. Clearing Jams .....	43
<b>4.3. Routine Maintenance</b> .....	<b>44</b>
4.3.1. Cleaning the Series 410 Envelopener™ .....	44
4.3.2. Replacing the Print Cartridge .....	47
4.3.3. Cutter Adjustment .....	49
4.3.4. Resetting the circuit breaker .....	51
<b>4.4. User Replaceable Parts</b> .....	<b>53</b>

---

---

## 4.1. Operation

---

---

### 4.1.1. Machine Controls

#### 4.1.1.1. Keypad Button Functionality

The Series 410 controls are located on the keypad to the right of the LCD screen as indicated in Figure 4-1.

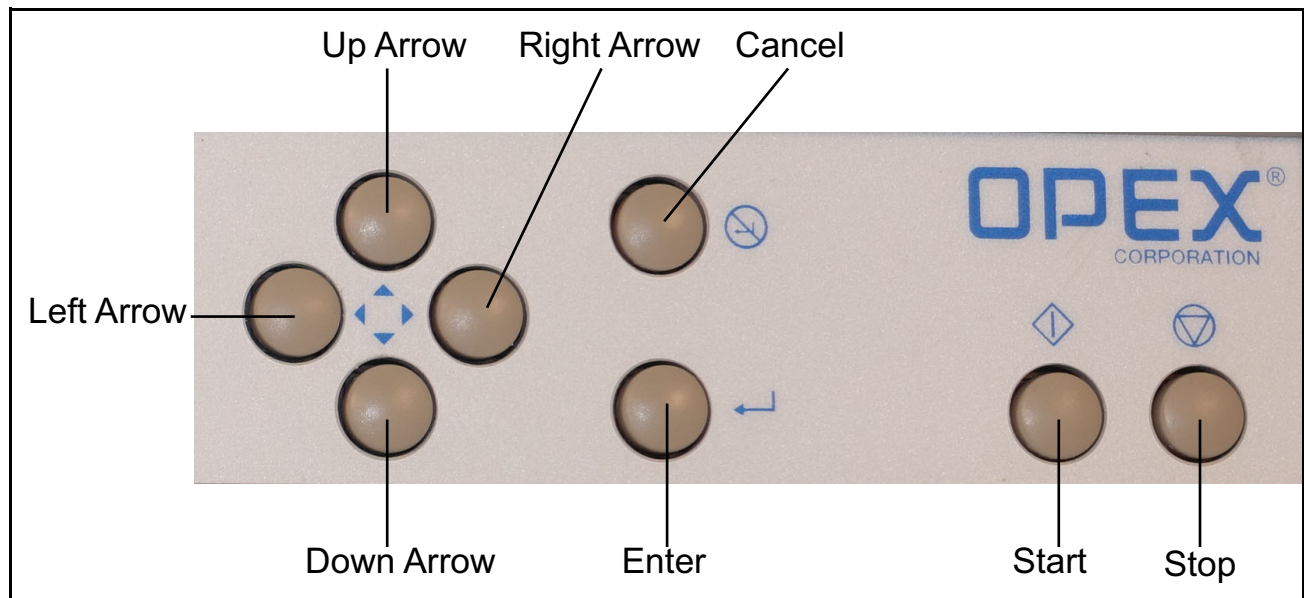

**Figure 4-1: Series 410 keypad button names**

**Start button** - used to turn on the Series 410.

**Stop button** - used to turn off the Series 410 display.

**Enter button** - used to make selections that are shown on the LCD display.

**Cancel button** - used to cancel actions (such as to stop a job run), or back out of a screen.

**Arrow buttons** - used to navigate through the data on the LCD screen.

#### **4.1.1.1.1. Arrow button functionality**

**Up Arrow Press** - will allow you to navigate up through a column of data. When the upper item within the column is highlighted and you press the up key, the list of data is shifted down by a row and the previous line of data is displayed. If the up arrow is pressed while on the first row of data, then the cursor will move left to the first item in the table. If the first item is selected, then the cursor will move to the last item in the list.

**Up Arrow Hold** - Pressing and holding the up arrow will display the previous full page of data. The screen will wrap to the last page of data when you hold the up arrow while the first page of data is displayed. When the screen wraps to the last page, the last item in the list will be highlighted.

**Down Arrow Press** - will allow you to navigate down through a column of data. When the lower item within the column is highlighted and you press the down arrow, the list of data is shifted up by a row and the next line of data is displayed. If the down arrow is pressed while on the last row, the cursor will move left to the last item in the table. The screen will wrap to the first item in the list if you press the down arrow when the last item in the list is highlighted.

**Down Arrow Hold** - Pressing and holding the down arrow will display the next full page of data. The screen will wrap to the first full page of data when you hold the down arrow while the last page of data is displayed. The first item in the list will be selected when the screen wraps to the first page.

**Left Arrow Press** - will shift the highlighted selection one column to the left. If the selected item is in the first row and the left arrow is pressed, then the last item in the previous row will be selected. In addition, if the first item on the page is highlighted and the left arrow is pressed, the list is shifted down and the previous line of data is displayed. Pressing the left arrow while the first item on first page is highlighted will cause the screen to wrap to the last item in the list.

**Left Arrow Hold** - Left arrow hold will continuously shift the selection one item to the left until the key is released. It will work the same as the left arrow press.

**Right Arrow Press** - will shift the highlighted selection one column to the right. If the selected item is in the last row and the right arrow is pressed, then the first item in the next row will be selected. In addition, if the last item on the page is highlighted and the left arrow is pressed, the list is shifted up and the next line of data is displayed. Pressing the right arrow while the last item on the last page is highlighted will cause the screen to wrap to the first item in the list.

**Right Arrow Hold** - will continuously shift the selection one item to the right until the key is released. It will work the same as the right arrow press.

## 4.1.2. The Run Screen

All of the basic Operator functions can be accessed right from the Run screen.

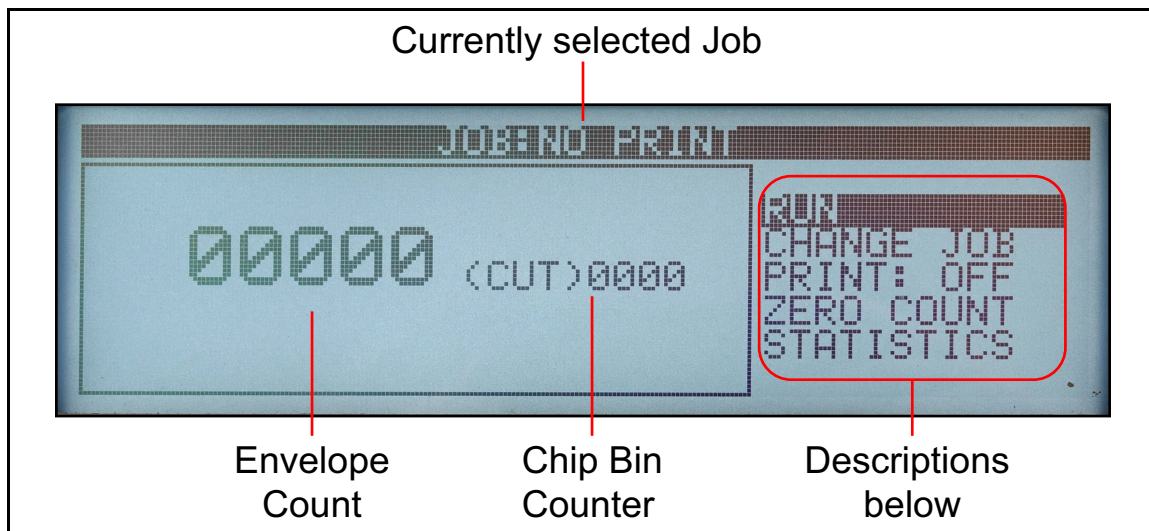

**Figure 4-2: Run screen**

Run screen information:

- The run screen will show overall Envelope counts with the large counter
- The smaller (**CUT**) counter is how many envelopes have been cut, and is reset every time the chip bin is removed

### 4.1.2.1. RUN

This selection will turn the motor on to process mail using the currently selected job.

### 4.1.2.2. CHANGE JOB

This selection will allow the operator to change the currently selected job.



### 4.1.2.3. PRINT

In jobs that have printing enabled, this will be set to **ON**. This will allow the operator to temporarily turn audit trail printing off and on. This capability was provided in case there is an issue with the printer and the operator wants to run mail without correcting that issue. Printing cannot be turned on if running the No Print job.

**Note:** When turning printing back on, the machine will ask if you want it to “spit”. This means the printer will spray a small mark, as a quick way to clear the print nozzles. You should have a piece of paper under the print head when doing this.

#### 4.1.2.3.1. Print Head Cleaning

The **SPIT** option appears before **ON** when cycling through the print options. This sprays ink from the print nozzles as a way to clean the heads of the cartridge.

The print nozzles can be cleaned by placing a piece of paper under the print head selecting **SPIT**, and pressing the **down arrow**.

### 4.1.2.4. ZERO COUNT

This will allow the user to reset the statistics counters for the current run. At the beginning of a run or at any point during a run, a user may reset the counters. This will cause the software to zero all of the counts on the screen, close out the current statistics “record,” and open up a new one.

### 4.1.2.5. STATISTICS

This will show the **DISPLAY STATISTICS** screen, which will allow the user to display and optionally print their statistics (Figure 4-3).

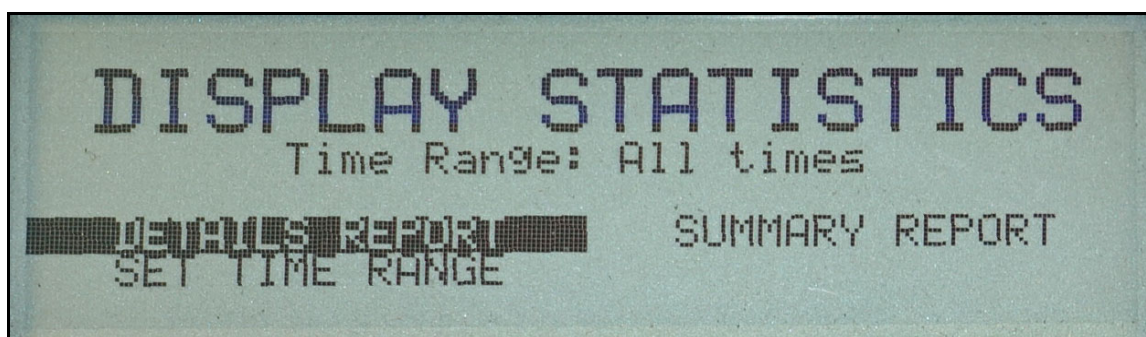
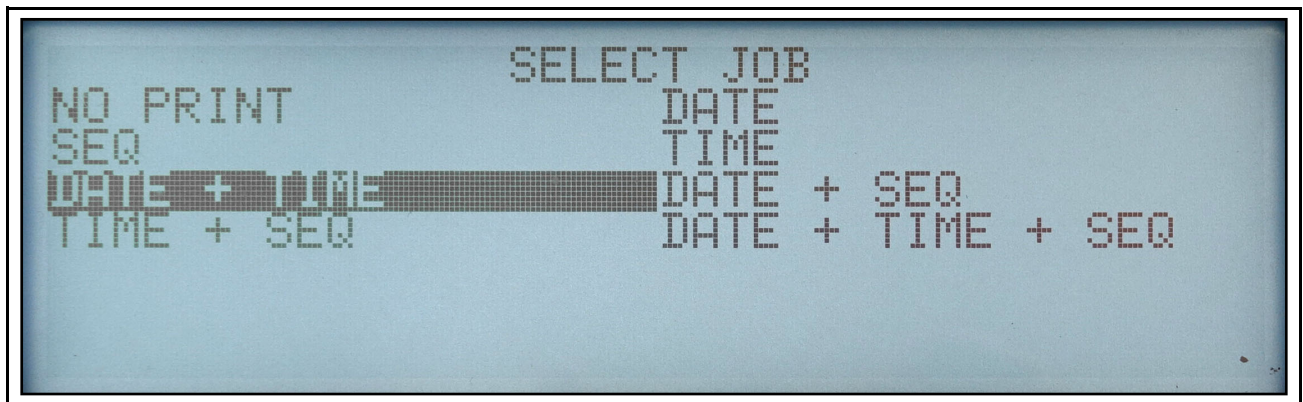

**Figure 4-3: Display Statistics screen**

- **DETAILS REPORT** - Pulls together all jobs run in the specified time range in their each individual view (example: if the operator ran four jobs, the data will be pulled together into four views).
- **SUMMARY** - Pulls together all jobs run within the specified time range in one view.
- **SET TIME RANGE** - allows operator to set specified date and time for pulling the above information together.

#### 4.1.2.6. Printing on the Envelopes

Through the Select Job menu (Figure 4-4), the Series 410 can be set to print the date, the time a piece was processed, its sequence number, or any combination of the three.



**Figure 4-4: Printing via Jobs**



---

## 4.2. Operating Instructions

---

### 4.2.1. Order of Operation

1. Connect the power cord to the OMATION® Series 410 Envelopener™ and into an AC supplied outlet.
2. Connect the output tray on the right side of the machine (as shown on [page 42](#)).
3. Press the “1” position on the AC power switch on the left side of the machine to supply power to the machine (Figure 4-5).



**Figure 4-5: AC power switch**

4. Press the **Start button** to turn the machine on (Figure 4-6). This will bring up the **RUN** screen.

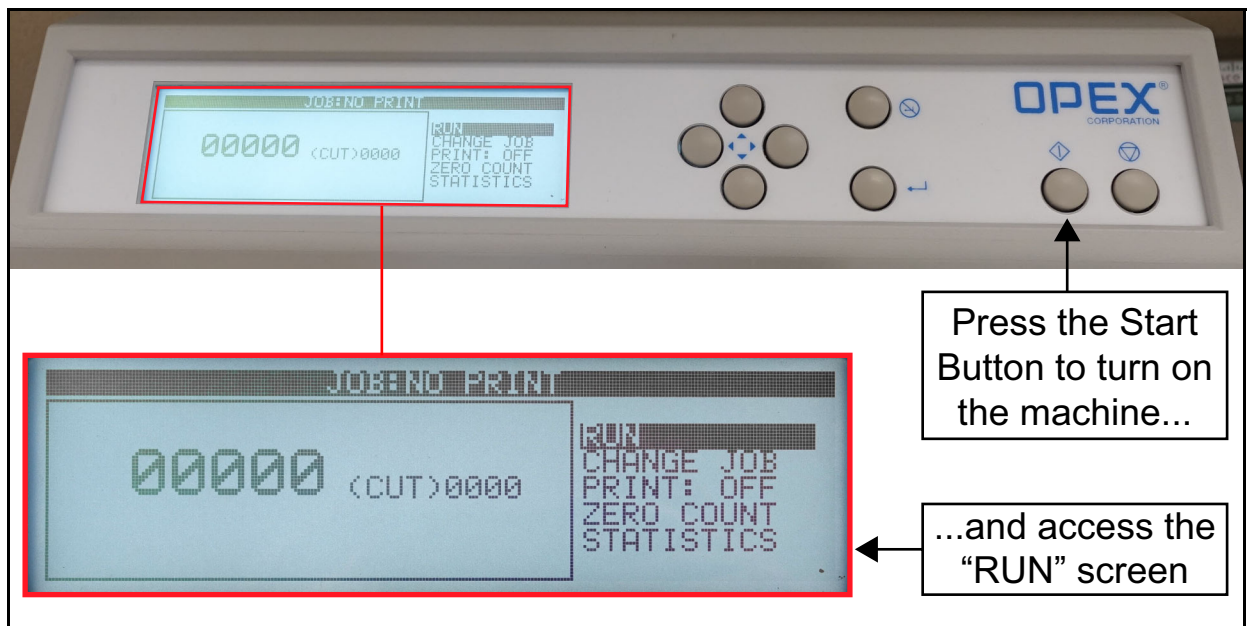

**Figure 4-6: Start Button**

5. Use the arrow buttons to highlight **ZERO COUNT**, then press the **Enter button** to reset the count (Figure 4-7).

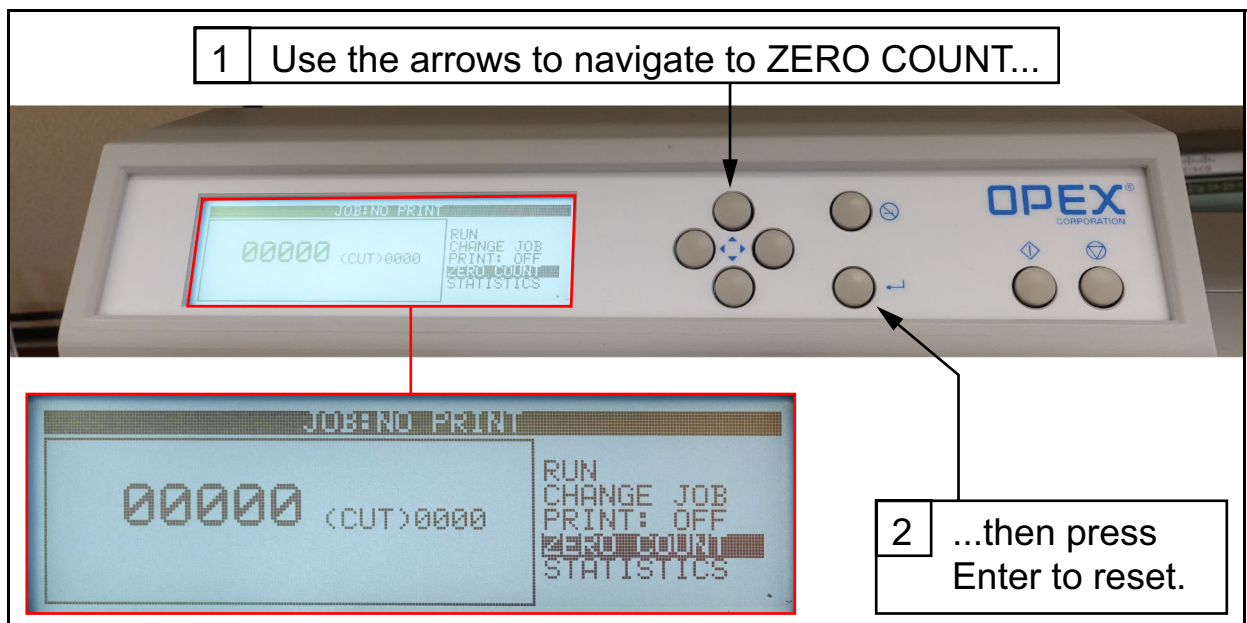

**Figure 4-7: Resetting the counter**

6. Access the **Select Job** screen by using the **arrows** to highlight **CHANGE JOB** in the menu, and then press the **Enter** button (Figure 4-8).

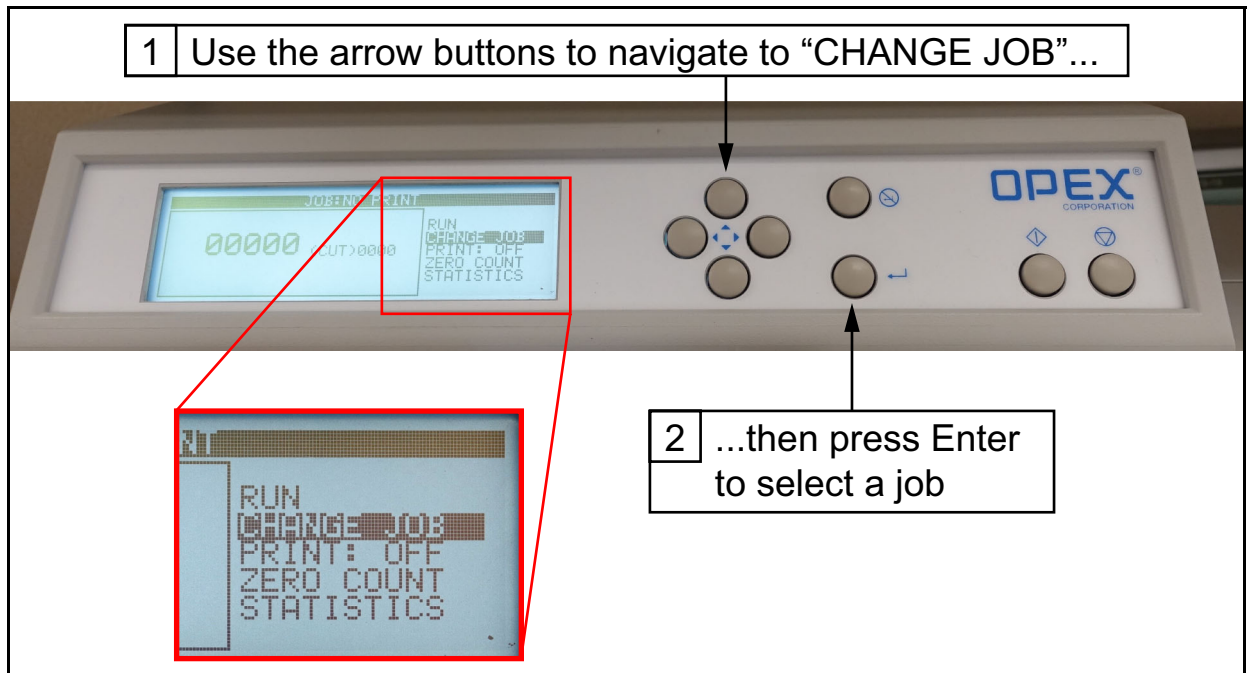

**Figure 4-8: Getting to the Select Job screen**

7. Select a job by highlighting it with the **arrow buttons**, and then pressing **Enter** (Figure 4-9).

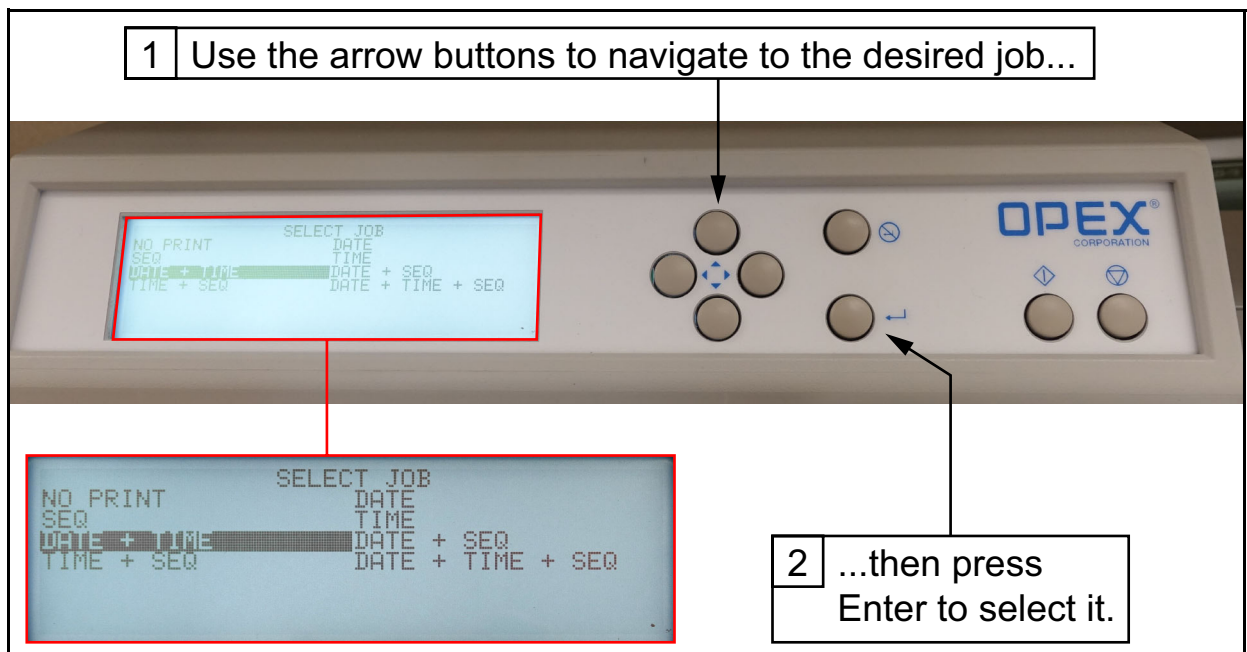

**Figure 4-9: Selecting the Date + Time job**

- The display will return to the **Run** screen, with the job name displayed at the top. At this time, you should set the cutter depth knob (Figure 4-10) for the desired cut. Position 1 is the shallowest cut, and 3 is the deepest.



**Figure 4-10: Setting the cut depth**

- Once ready to begin, use the arrow buttons to highlight **Run**, and then press Enter to start the machine (Figure 4-11). The screen will display “RUN MODE ACTIVE” and elapsed run time.

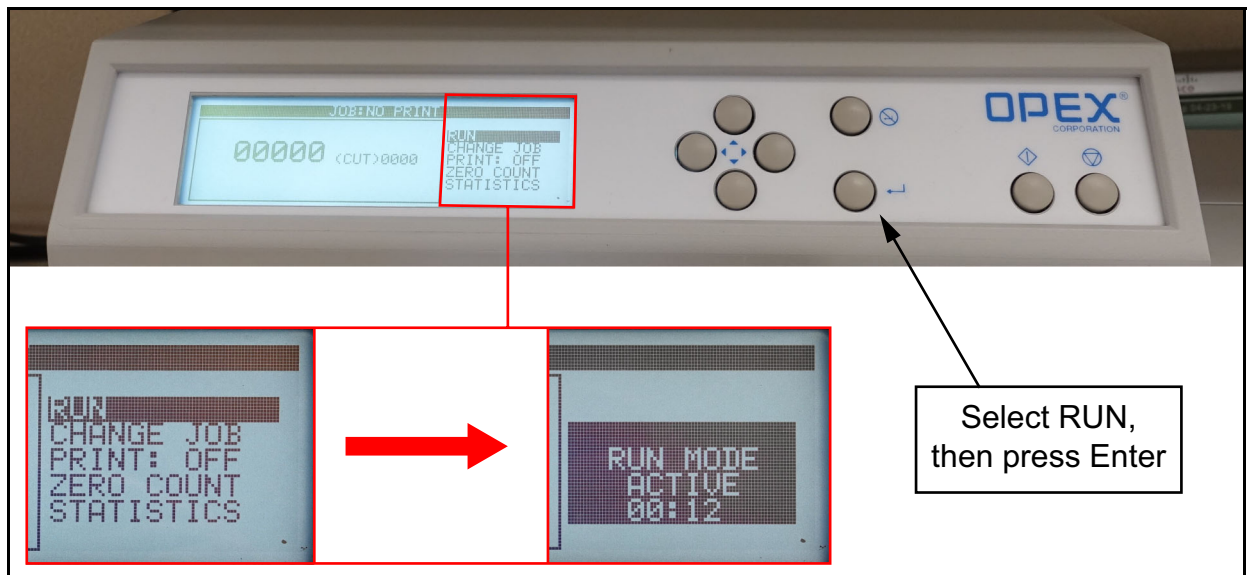

**Figure 4-11: Starting the machine**

10. Load a handful of mail (approximately 25-50 pieces) onto the Envelope Feed Hopper. Be sure the top side of the mail to be cut is even against the back of the Feed Hopper. The Feed Thumper (a rotating cam) helps to jog the mail for improved feeding.
  11. The conveyor belt pulls the mail into the retard assembly where it is singulated (separated one at a time).
  12. The nip arm assembly guides the individual envelope under the printer where the envelope can be printed on, if a print job option is selected.
  13. The envelope then passes under the cutter which will open it if the cutter depth knob is set for one of the cut options.
  14. The envelope is then passed through the counter sensor and counted (the mail is always counted even if it is not cut).
  15. The envelope then moves into the mail output tray.
  16. Once the Envelope Feed Hopper is empty, empty the output tray.
  17. To continue processing, load more mail onto the Envelope Feed Hopper.
- Note:** *The feed hopper can be loaded with the machine running.*



## 4.2.2. Output Tray Position

The position of the output tray can be adjusted for processing larger envelopes. Simply lift the output tray up, move it to the desired position, and press it down onto the stepped tray hitch (see Figure 4-12).

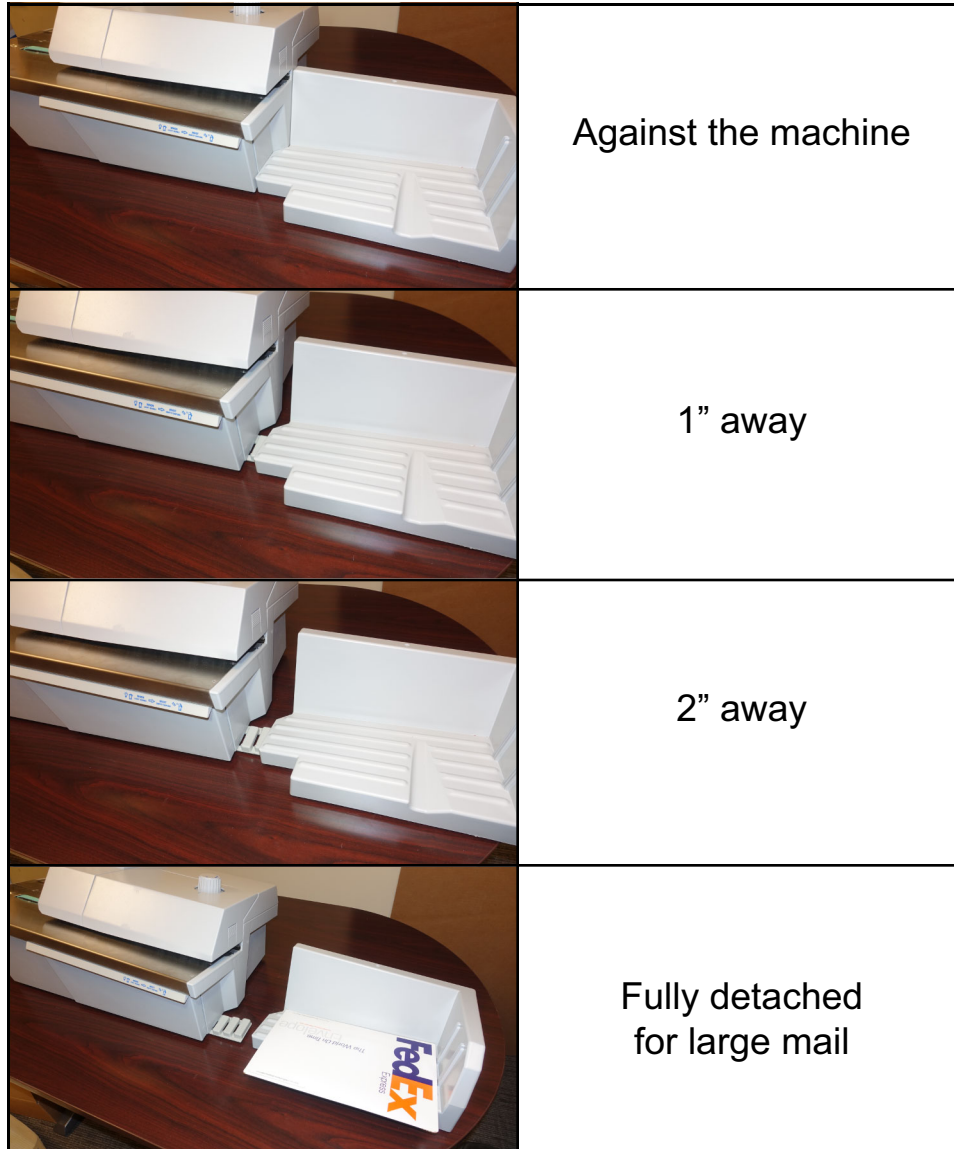

**Figure 4-12: Output tray positions**

### 4.2.3. Clearing Jams

From time-to-time, you will experience the inevitable jam. A “jam” refers to any occurrence that causes the machine to stop, not necessarily because an item is physically jammed in the machine. You may have to remove the nip arm cover. This is described in [“Routine Maintenance” on page 44](#).

---

## 4.3. Routine Maintenance

---

It is important that you keep your machine clean and in good working order. This will prolong the overall life of the machine and result in longer periods of “up” time. Therefore, you should perform the following tasks once per day:

### 4.3.1. Cleaning the Series 410 Envelopener™

1. Unplug the power cord.
2. Press the catch release button on the right side of the cover until a “click” is heard and lift the right side (Figure 4-13).

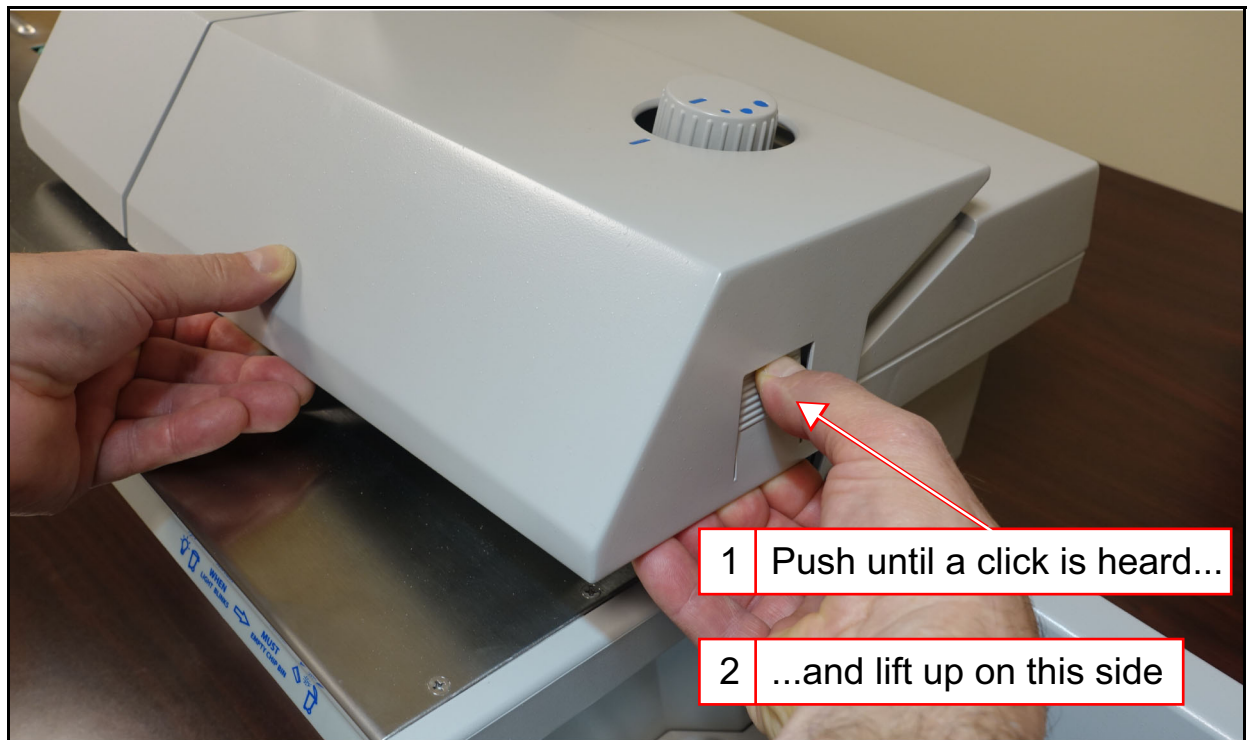

**Figure 4-13: Cover catch release button**



3. Continue lifting the cover off on the left side to remove it (Figure 4-14).



**Figure 4-14: Lifting the Nip arm cover**

4. Lift the Nip arm wheels to clean under them (Figure 4-15).



**Figure 4-15: Lifting the nip wheels**

5. Remove and empty the chip bin.
6. Vacuum loose paper chips and debris from the machine.
7. Use a cloth moistened with liquid cleaner to wipe down the exterior of the machine.
  - Use denatured alcohol on areas with stains, if necessary.
  - Any non-flammable commercially available cleaning solution may be used to clean the machine. When cleaning the Opex OMATION<sup>®</sup> Series 410 Envelopener<sup>™</sup>, DO NOT USE aerosol cleaners or compressed air because of the flammable nature of many of these products. There is a risk of equipment malfunction and/or injury associated with the use of aerosol cleaners on OPEX equipment prior to the operation of equipment.
  - When cleaning glass and plastic surfaces, use detergent-based cleaners such as Fantastic<sup>™</sup> or Formula 409<sup>™</sup>. Detergent-based cleaners are recommended, because they do not cause component degradation.



### CAUTION

A cloth soaked with cleaning detergent or similar material should never be used to clean an object such as a belt or roller when the belt or roller is being driven by the system. Use of a cloth or similar material on moving mechanisms can result in personal injury. If a belt, pulley or similar part needs to be cleaned, it should be cleaned while stationary or unplugged.

- Wipe dust and debris from the sensors. Debris build-up can cause jams. Accumulations of dirt and debris can cover sensors, preventing them from working effectively. This will hinder machine performance.
8. Re-install the chip bin and nip arm cover.

## 4.3.2. Replacing the Print Cartridge

If the print becomes faded on the envelopes, the print cartridge may need to be replaced. To replace the printer cartridge:

1. Either unplug the AC power cord, or turn off the AC power switch on the left side of the machine.
2. Remove the Nip Arm Cover (as shown on [page 44](#)) to expose the printer cartridge (Figure 4-16).

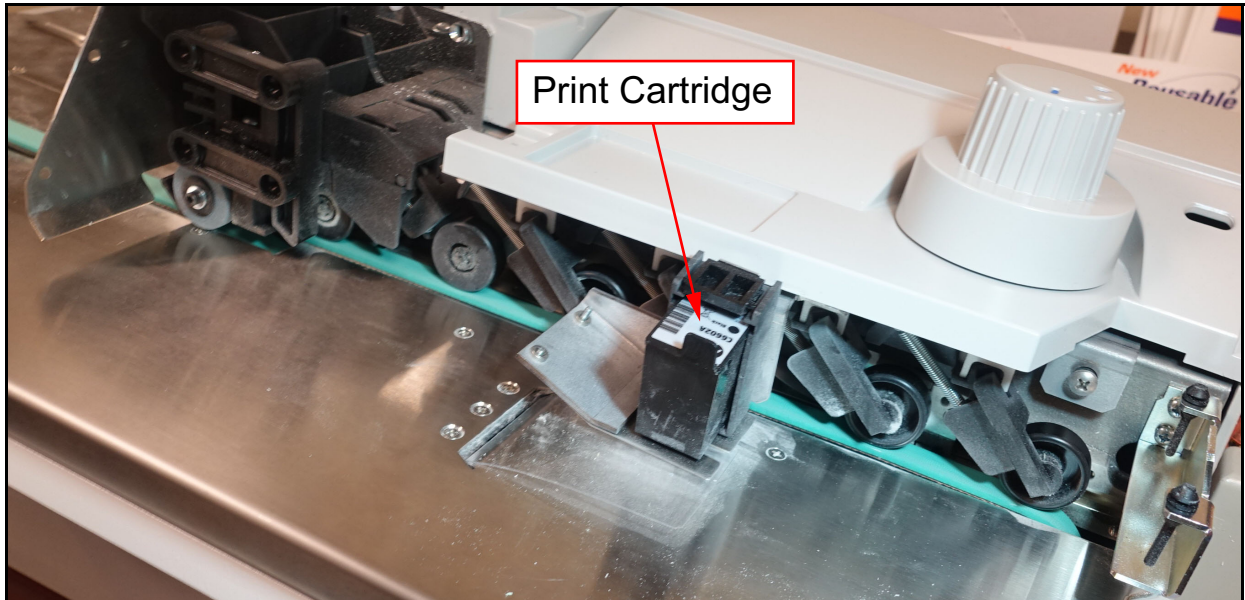

**Figure 4-16: Printer Cartridge**



3. Grasp the tab on the printer cartridge and pull in an arc motion (Figure 4-17).

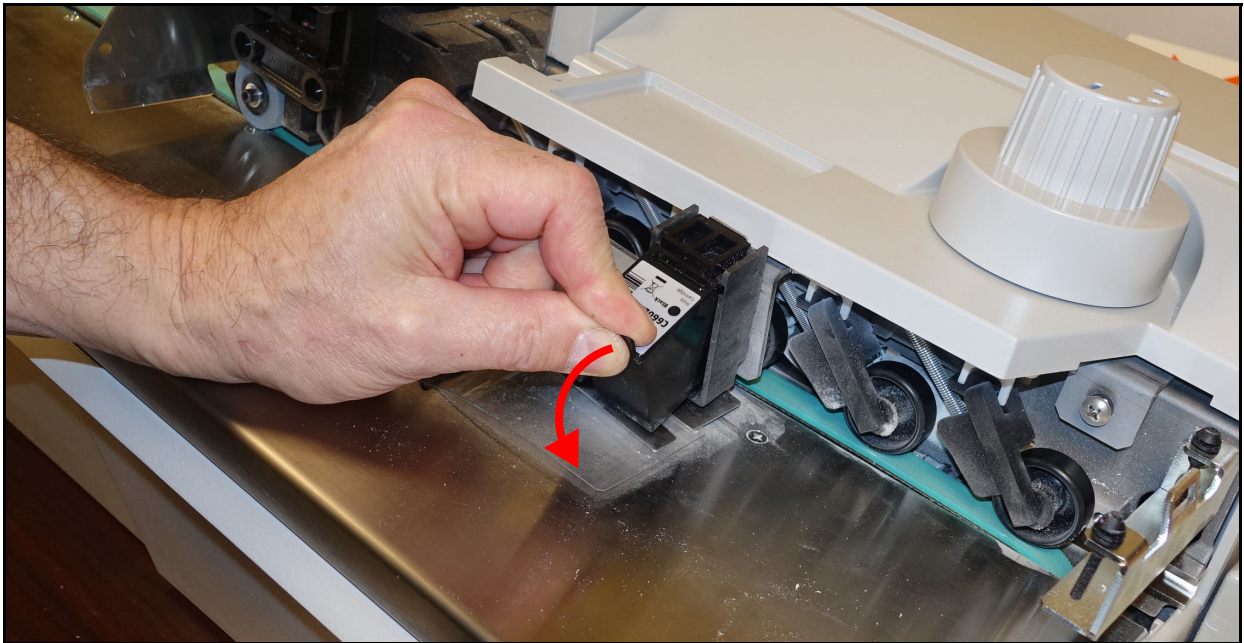

**Figure 4-17: Removing the print cartridge**

4. Replace the printer cartridge and push into place (Figure 4-18).



**Figure 4-18: Replacing the printer cartridge**

5. Replace the Nip Arm Cover and run a printing job to test the printer.

### 4.3.3. Cutter Adjustment

The cutter depth has been adjusted from the factory and should not need to be adjusted. If you find that mail is not being opened on cutter setting 1 and 2, the cutter can be adjusted.

#### To adjust the cutter depth:

1. Set the Cut knob to the “**Standard Cut**” position (Figure 4-19). This position should always cut standard mail deep enough to remove the contents but **not cut** any of the contents. This position will be our reference. The other positions will all be adjusted when this is changed.

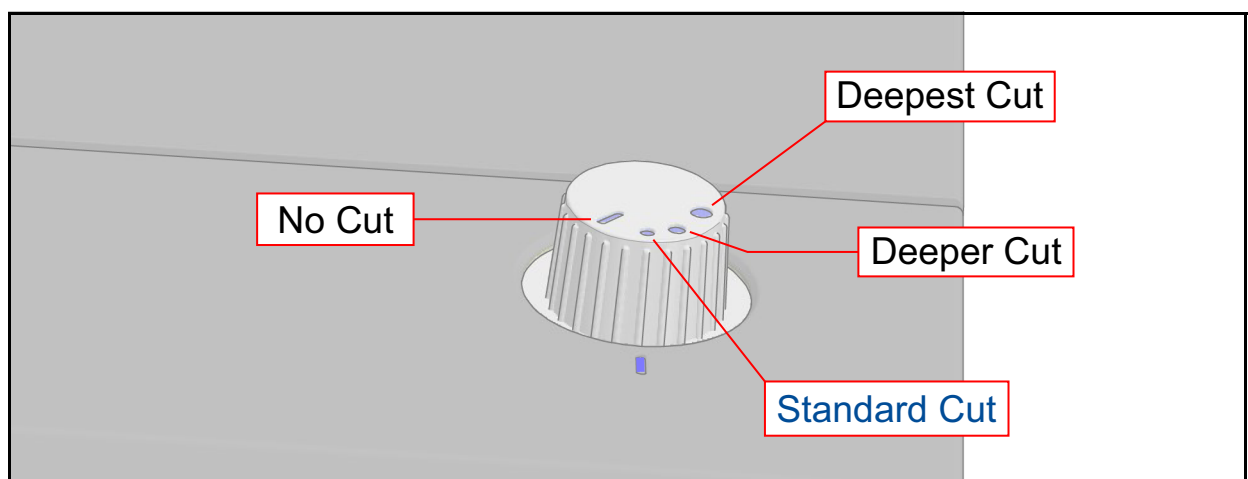

**Figure 4-19: Standard Cut position**

2. Remove the nip assembly cover (see [“Cleaning the Series 410 Envelopener™” on page 44](#)).

3. The depth of the cutter can be fine adjusted by turning the cutter depth screw (Figure 4-20). Using a Phillips screwdriver, turn the screw in 1/4-turn increments, to the right for a deeper cut, or to the left for a shallower cut.

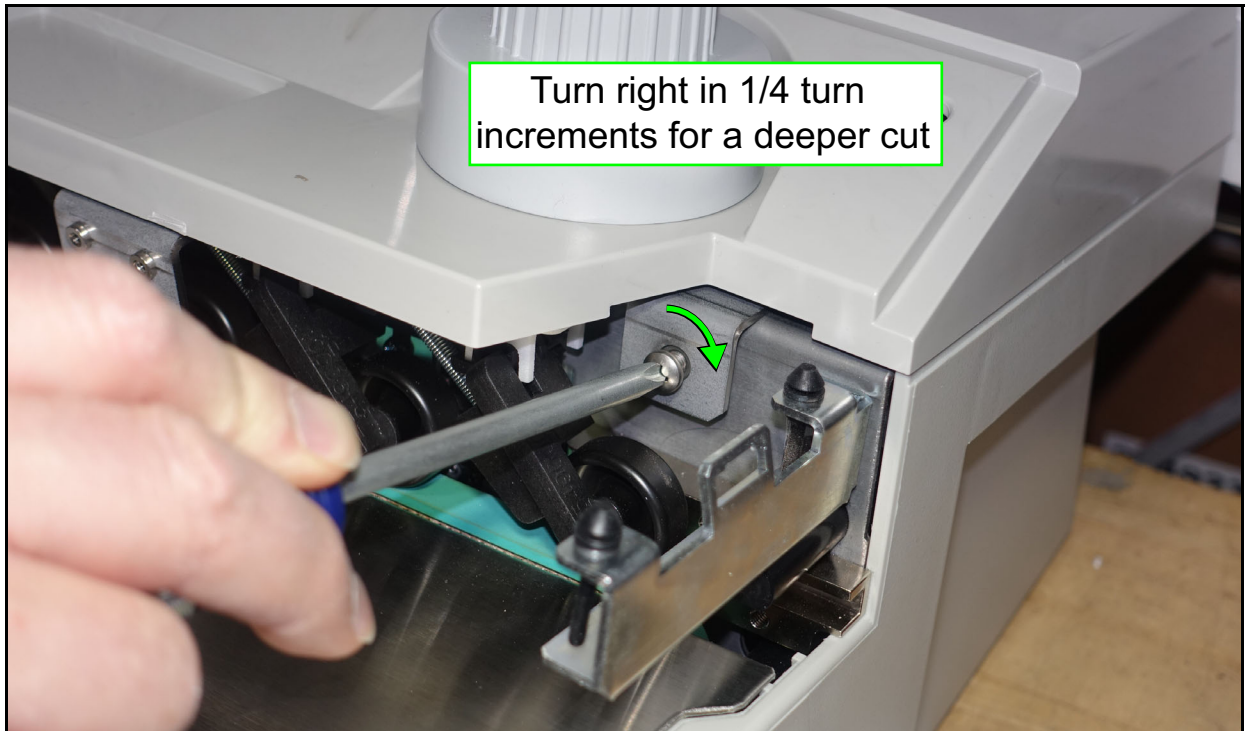

**Figure 4-20: Adjusting the cutter depth**

4. Replace the cover and run an envelope through to verify if it has been cut now.
5. If envelopes are not being cut, repeat steps 1 through 4 as needed. Increments smaller than 1/4 turn can be used to fine tune the cutter.



### 4.3.4. Resetting the circuit breaker

1. If the machine has no display and is plugged in and turned on, check the circuit breaker on the back of the machine. The breaker shown has been tripped and is open (Figure 4-21).

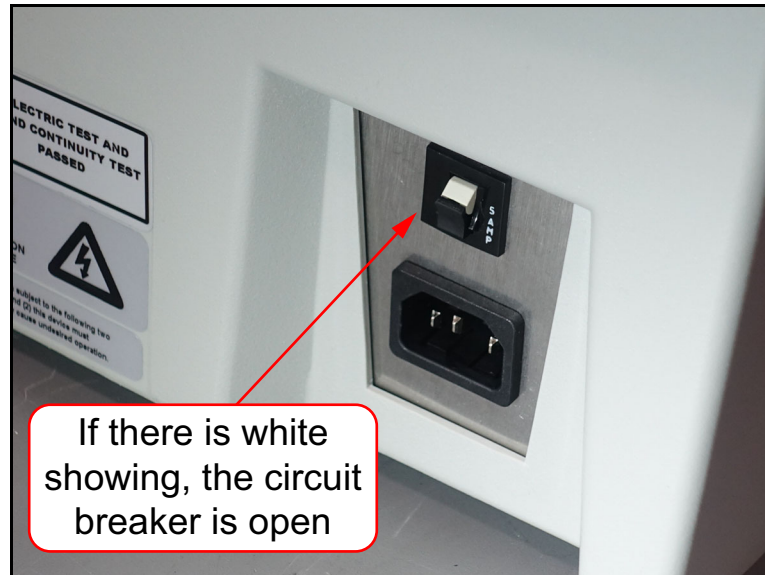

**Figure 4-21: Open circuit breaker**

2. Unplug the power cord and push the circuit breaker toward the machine to close it (Figure 4-22).

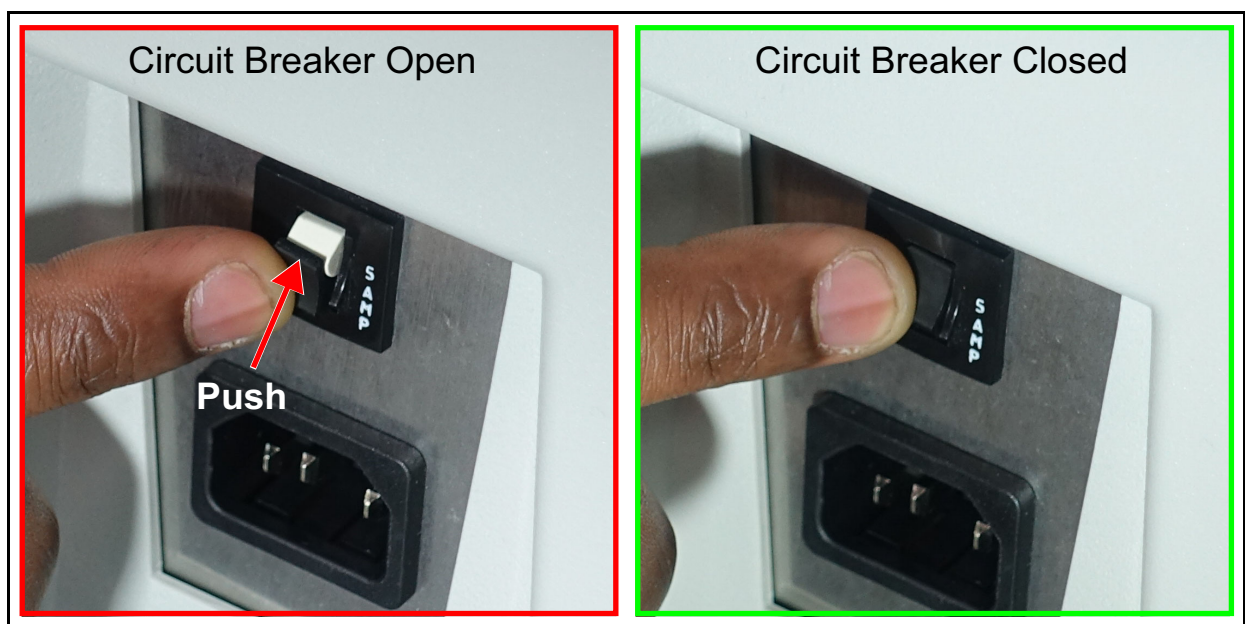

**Figure 4-22: Closing the circuit breaker**

3. Plug the power cord back into the machine.
4. Verify the machine has a power display and operates normally.  
If the circuit breaker pops back out, call OPEX Tech Support to have the machine serviced (See [“Contacting OPEX” on page 2](#)).



---

## 4.4. User Replaceable Parts

---

The parts on the following pages can be replaced by the user. If you're viewing the electronic version of the manual on a tablet, click or tap the circle pointing to the part to skip to its page (Figure 4-23).

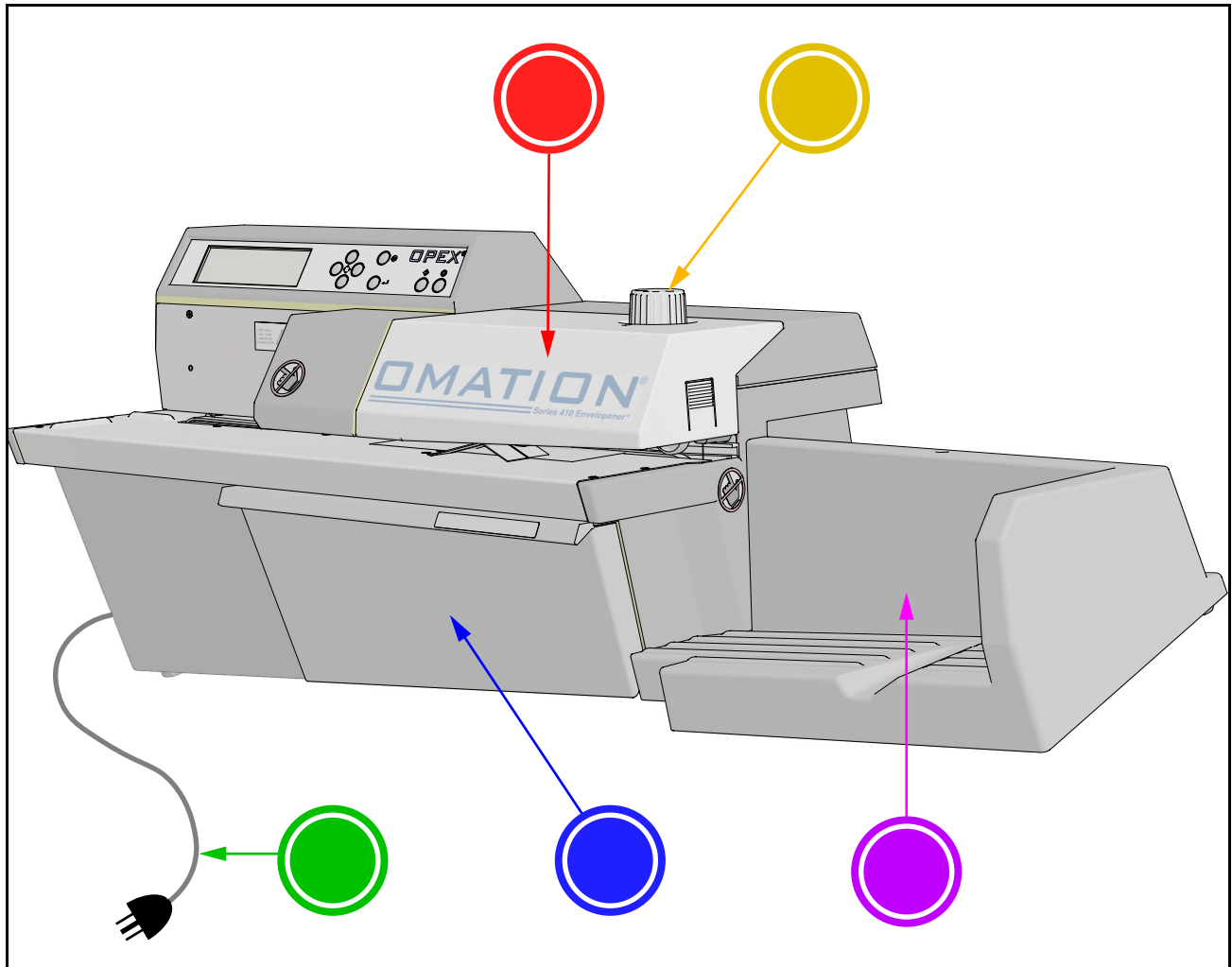

**Figure 4-23: User Replaceable Parts**

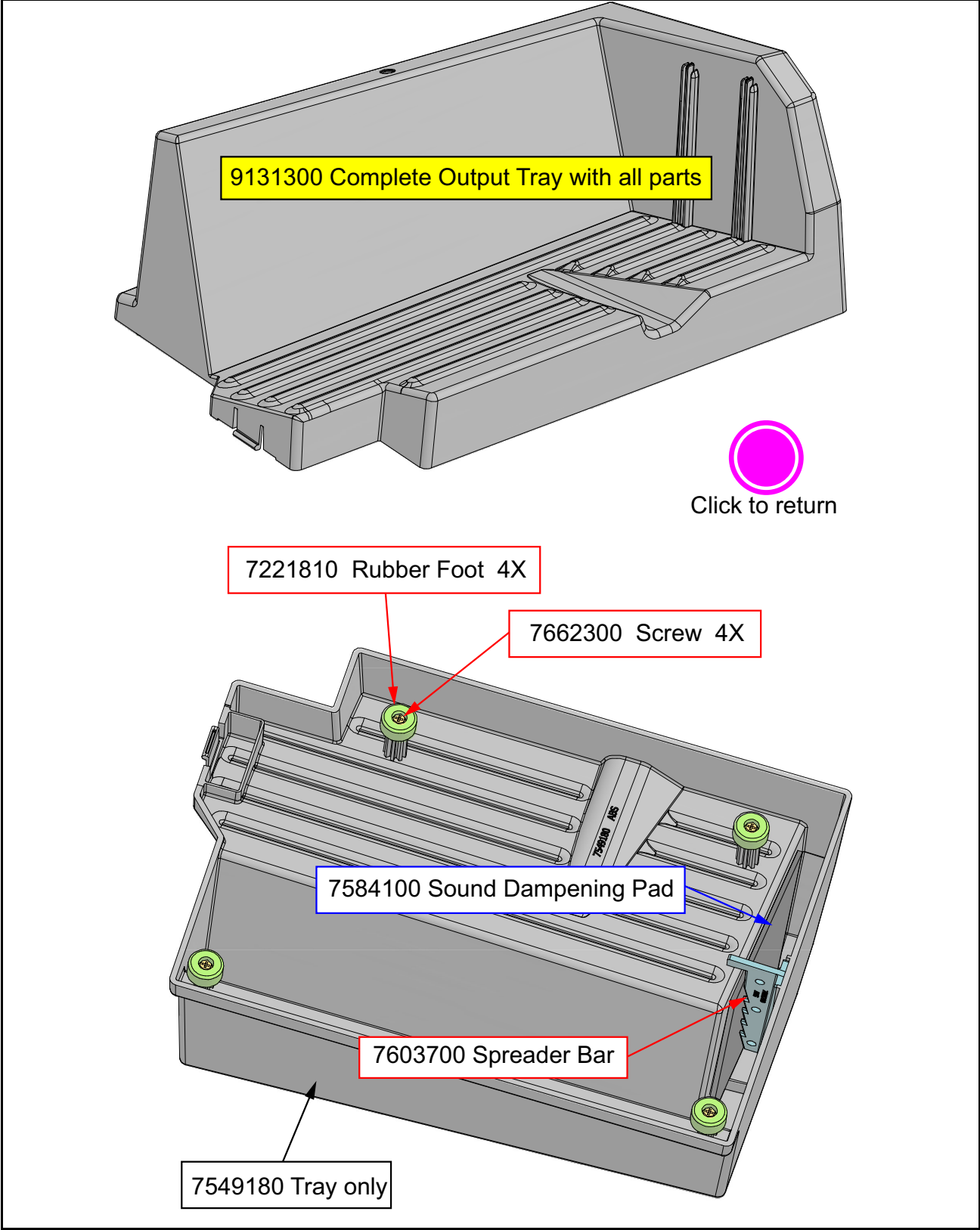

**Figure 4-24: Output Tray Assembly**

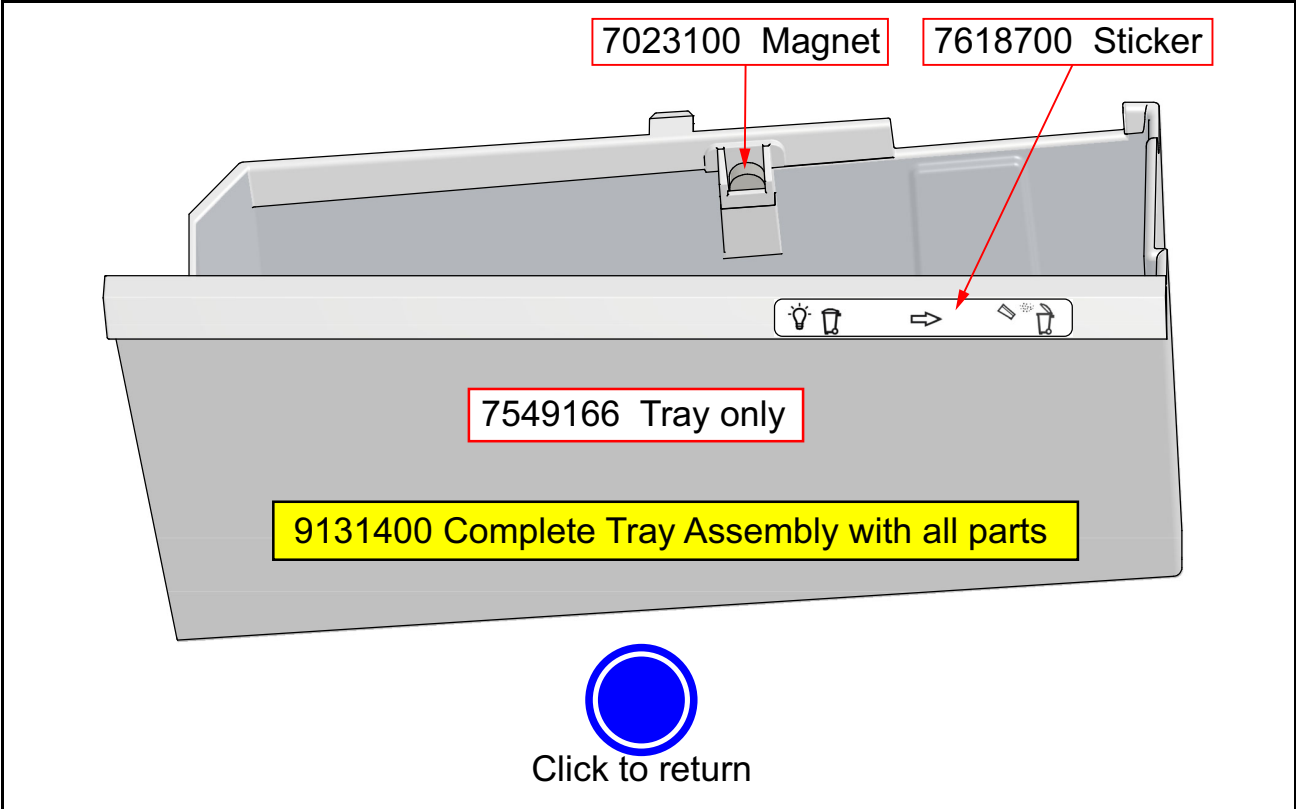

**Figure 4-25: Chip Bin Tray Assembly**

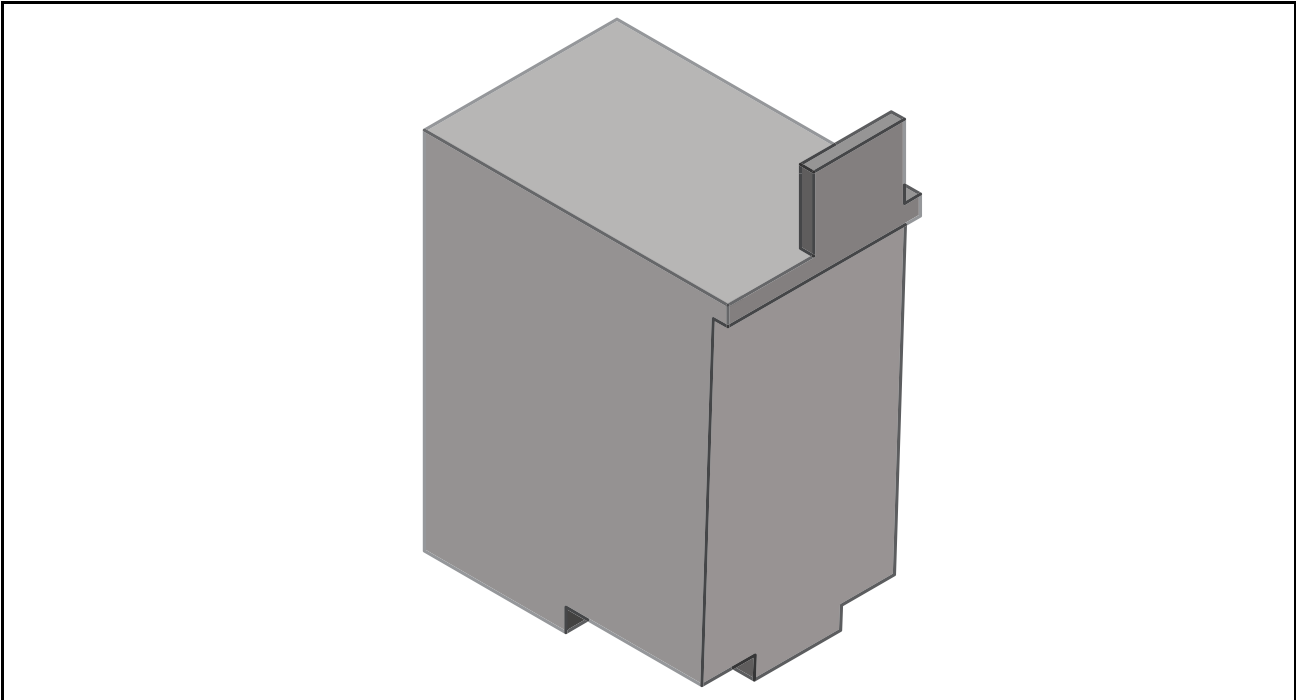

**Figure 4-26: 3387500 Printer Cartridge (under transport cover)**

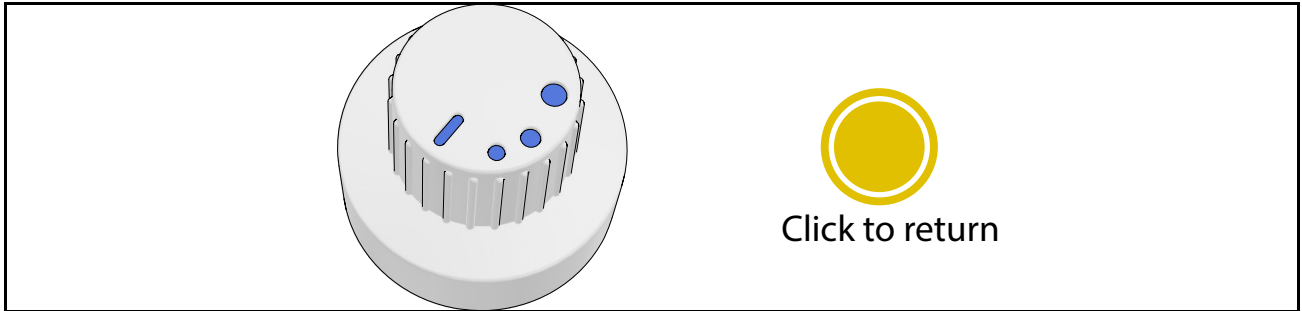

**Figure 4-27: 8067050 Cutter Depth Knob**



**Figure 4-28: 8096750 Transport Cover**

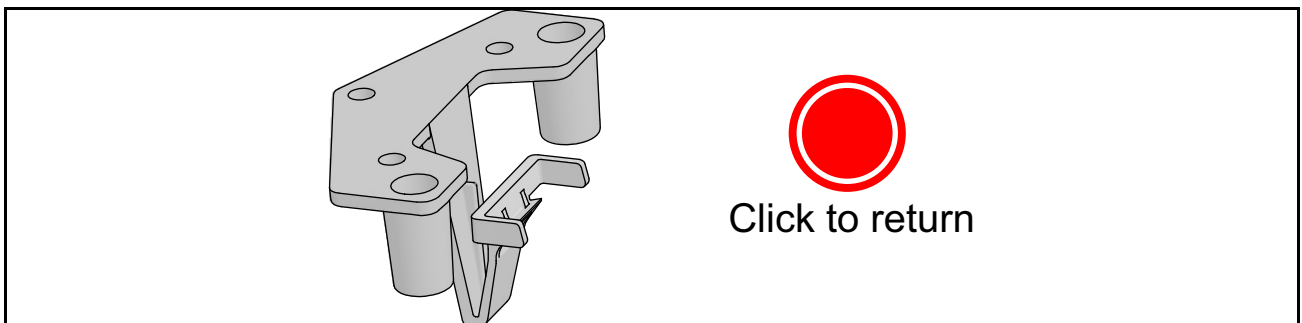

**Figure 4-29: 8069225 Transport Cover Latch (under transport cover)**

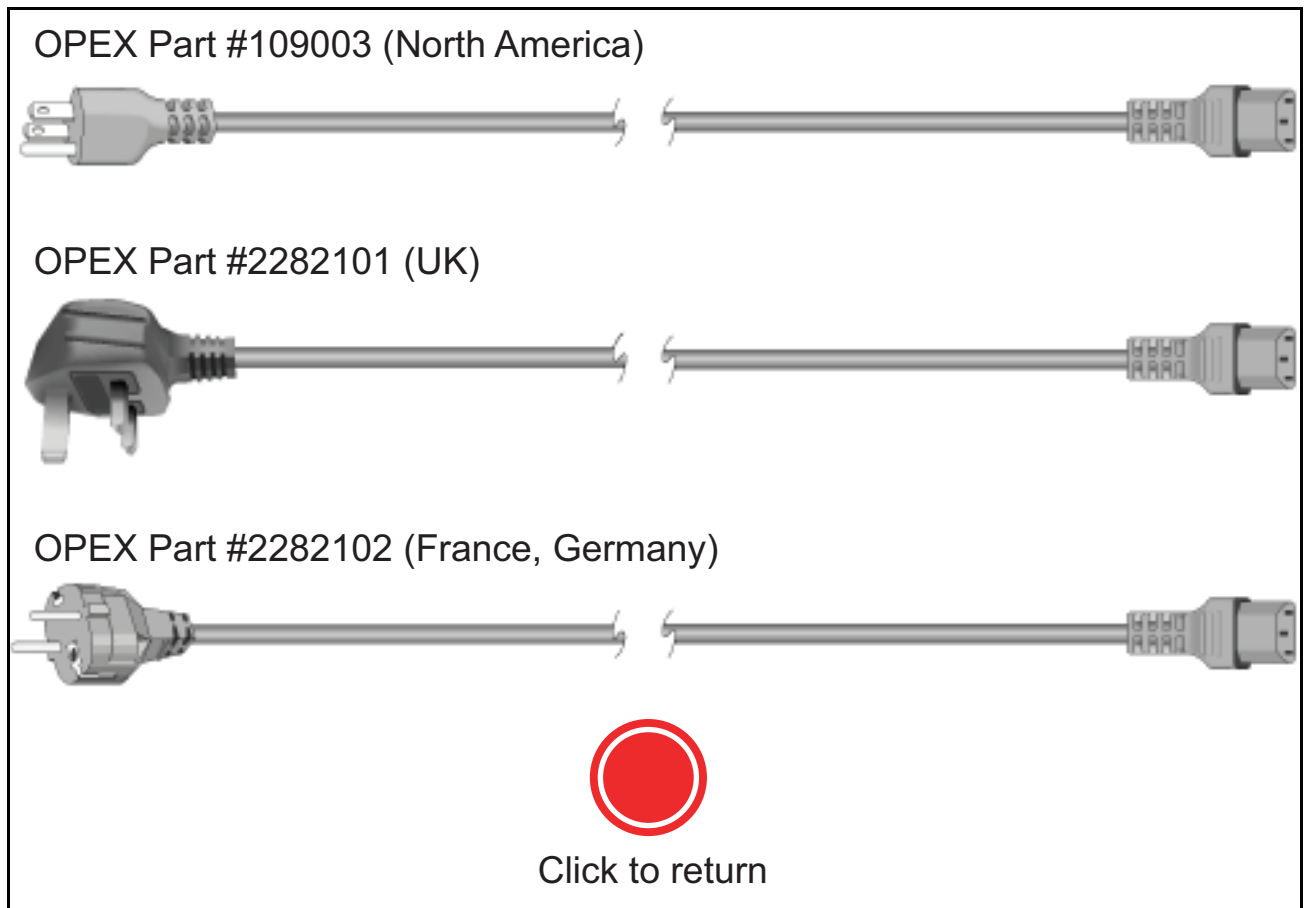

**Figure 4-30: AC Power Cords**

**Table 4-1: Additional Power Cords**

Country	Part Number
Australia	# 109008
Denmark	# 109015
India, South Africa	# 109016
Switzerland	# 109018
Italy	# 109019
Japan	# 2952200

This page intentionally left blank

# 5. Specifications

5.1. Physical Specifications .....	60
5.2. Features .....	60
5.3. Electrical Requirements .....	61
5.4. Environmental Specifications .....	61

## 5.1. Physical Specifications

Specification	Value
Length	40.5" – 42.5" (1028.7 mm – 1079.5 mm)
Depth	16.5" (419.1 mm) or with power cord 18" (457.2 mm)
Height	14.3" (363.22 mm)
Weight	51 lbs (23.59kg)

## 5.2. Features

Specification	Value
Speed	Up to 400 envelopes / minute (using 6" envelopes)
Envelope Sizes & Types	Min. length: 3.50" Max. length: 14.00" Min. height: 3.00" Max. height: 9.50"
Thickness	Up to 0.188" (4.8 mm)
Cutter Settings	Cut depths range from 0.01"- 0.07". (0.25mm - 1.79mm) <b>Default settings</b> No-cut setting, Cut depth 1 = 0.010" (0.254mm) Cut depth 2 = 0.014" (0.356mm) Cut depth 3 = 0.060" (1.524mm) The cut adjustment screw changes the cut depth 0.0044" for every ¼ turn of the screw.
Printer	Prints, Date, Time, and Sequence number



## 5.3. Electrical Requirements

Specification	Value
Power	US: 110-120 VAC, 60HZ, 5A EURO: 220-240 VAC, 50HZ, 3A JAPAN: 100 VAC, 50/60HZ, 3A

## 5.4. Environmental Specifications

Specification	Value
BTU Rating	US: 1964 BTU/h (max @ 115v/5A) EURO: 2357 BTU/h (max @ 230v/3A) JAPAN: 1024 BTU/h (max @ 100v/3A)
Operating and Storage Temperature range	40°F – 100°F(4.4°C – 37.8°C), Humidity 10 – 90% Non-condensed.
Decibel Rating	Does not exceed safety standard of 80 dB.

This page intentionally left blank.

# G. Glossary

**OMATION® Series 410 Envelopener™**

**Operator Manual**

---

---

## G.1. List of Terms

---

---

The following list of terms, used throughout the OMATION® Series 410 Envelopener™ documentation, is sorted alphabetically.

**Cam** - A rotating wheel with the axle not in the center, transforming rotary motion into linear motion.

**Chip bin** - Collects cuttings discharged from the cutter.

**Circuit breaker** - A device that acts as a fuse but can be reset by pressing it.

**Cutter depth knob** - Knob to set the depth of cut.

**Denatured alcohol** - A type of alcohol that can be used for cleaning the outer surfaces of the machine that leaves no residue.

**Envelope Feed Hopper** - This area is where the envelopes are stacked to be fed into the retard assembly.

**Envelopener** - A machine that opens envelopes.

**Feed Thumper** - A rotating cam that helps to jog the mail for improved feeding.

**Feed belt** - This belt grabs the bottom envelope and pulls it into the retard assembly.

**Interlock** - A safety device that shuts the system down when tripped.

**Jam** - A problem with the system, typically (but not always) caused by a blockage.

**Milling cutter** - A cutter that chips away the edges of the envelope small bit at a time like a circular saw.

**Nip arms** - Rollers that keep the envelopes firmly pressed against the belt as they move past the cutter.

**Operator** - The person running the machine.

**Output tray** - Collects mail as it leaves the Series 410.

**Retard Assembly** - This separates the mail to one piece at a time as the stack of mail is pulled up to the entrance of the retard assembly.

**Singulate** - Separate or choose one at a time.

---

---

## About OPEX Corporation

---

---

For over four decades, OPEX has delivered forward-focused solutions for customers ranging from businesses aspiring to e-commerce success, to organizations striving for agility and profitability in a world that values speed and rewards service.

Throughout these 40+ years of leadership by the Stevens family, OPEX has forged a reputation for steadfast values: high quality, exceptional customer service, stability, stewardship and unwavering independence.

Utilizing a vast global workforce of direct employees, OPEX serves a variety of industries including financial services, insurance, healthcare, government, retail, non-profits, utilities, telecommunication, service bureaus, educational institutions and fulfillment operations.

To maintain our commitment to the highest standards of quality, we control all aspects of product design. Our combined Moorestown, NJ World Headquarters and Pennsauken, NJ production facilities feature 475,000 square feet of solar-powered engineering, manufacturing, warehouse, product assembly and office space.

**OMATION**<sup>®</sup>  
SERIES 410 ENVELOPENER<sup>®</sup>

