

*F601  
Booklet Feeder*

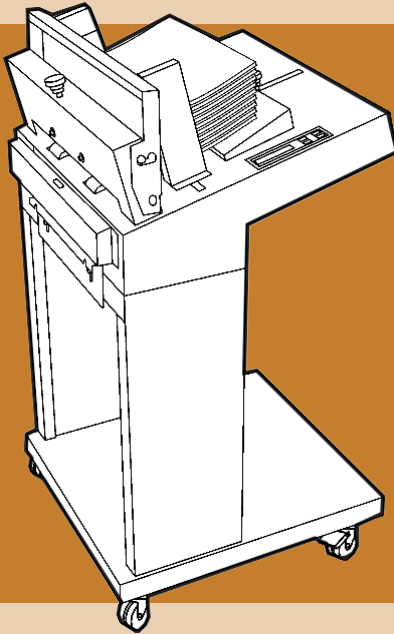

**DI875**

<b>1. Introduction</b>	page
1.1 Safety	2
<b>2. Getting to know the Model F601</b>	
2.1 Main components	3
2.2 The menus, flow chart	4
2.3 How to read the display	5
2.4 Explanation of the menus	5
<b>3. Operation</b>	
3.1 Setting up the Model F601	9
3.2 Adjusting the separation	10
3.3 Loading	10
3.4 Programming the Model F601	12
3.5 Start inserting	12
<b>4. Diagnostics</b>	
4.1 The Diagnostics function	13
<b>5. Maintenance</b>	
5.1 Cleaning the feed belts	13
<b>6. Problem solving</b>	
6.1 General problems	14
<b>7. Specifications</b>	
7.1 Model F601 Specifications	16

# Introduction

---

## 1. INTRODUCTION

This operator manual describes how to operate the Model F601 Booklet feeder.

### 1.1 Safety

#### *General*

- Know your equipment, especially **how to stop it in the event of an emergency**.
- Never reach into the machine while it is on; always wait until the machine has come to a full stop.
- Never touch moving parts.
- Keep fingers, long hair, jewellery and loose clothing away from moving parts at all times.
- Use the equipment only for its intended purpose.
- Don't remove machine covers. Refer servicing to qualified personnel.

## 2. GETTING TO KNOW THE F601

The Model F601 is a microprocessor controlled booklet feeder designed to be used in a system together with the Model F610 inserter and Model F612/F615 collator or as a stand-alone unit.

Take a few minutes to become familiar with components of the Model F601.

### 2.1 Main components

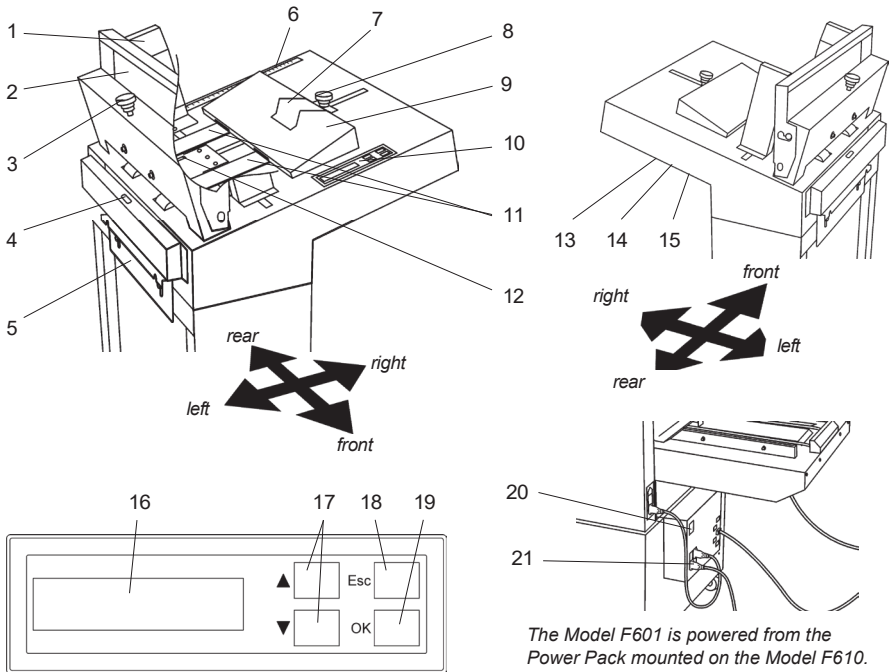

The Model F601 is powered from the Power Pack mounted on the Model F610.

- |                                     |                                  |
|-------------------------------------|----------------------------------|
| 1 Insert side guides                | 11 Insert feed belts             |
| 2 Insert front guide                | 12 Insert sensor                 |
| 3 Separator adjustment knob         | 13 Connection cable jack, female |
| 4 Outfeed sensor                    | 14 Termination plug jack, male   |
| 5 Docking plate                     | 15 Power cord receptacle         |
| 6 Length measuring scale            | 16 Display                       |
| 7 Rear guide pusher                 | 17 Arrow buttons                 |
| 8 Insert rear guide adjustment knob | 18 Escape button                 |
| 9 Insert rear guide                 | 19 OK button                     |
| 10 Control panel                    | 20 Ground fault interrupter      |
|                                     | 21 Main power switch             |



## 2.3 How to read the display

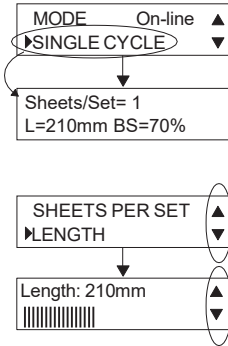

The arrow on the left side of the display shows which option is currently selected.

Pressing the OK button on the control panel confirms your selection and the corresponding submenu will appear in the display.

On the right side of the display, up and/or down arrows appear if there are more options that can be selected.

These arrows are also displayed when the value of the selected option can be increased/decreased using the arrow buttons. Use the up/down buttons on the control panel for selecting, scrolling or adjustment.

## 2.4 Explanation of the menus



Main Menu

The "Main Menu" is displayed with the option "START" selected when the Model F601 is switched on. The information in the display shows that the Model F601 is ready to start, it is (in this case) on-line with the system and the ID number in the system is one. See table below.

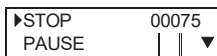

Run Mode Menu

Press the OK button on the control panel to confirm your selection and the Model F601 will start. If the F601 is installed in a system with a Model F610 Inserter and a Model F612/F615 Collator, the complete system can be started from any unit's start button. The "Main Menu" will be replaced with the "Run Mode Menu" when the Model F601 system is started.

### Units in the system

	Model F610	Model F601	Model F612/F615
ID number	2	1	not installed
	3	1	2
*	3	2	1
**	1	2	No power

\* If "Module Priority" in F601 is changed to ID no.2.

\*\* If the power is off to the Model F612/F615, a "Comm Error" is created. Turn on the power to the Model F612/F615 and select OFF-line or ON-line.

# The Feeder

## 2.4 Explanation of the menus (continued)

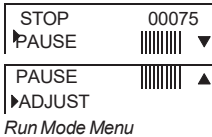

The “Run Mode Menu” is displayed when the Model F601 is started. In the “Run Mode Menu” there are three options: “STOP”, “PAUSE” and “ADJUST”. Scroll/select an option with the arrow buttons and confirm with the OK button.

“STOP”: The Model F601 (and attached units) completes the set being processed and then stops. You will be returned to the “Main Menu”.

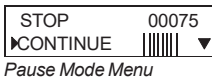

“PAUSE”: The Model F601 (and attached units) is paused immediately. The text “PAUSE” will be replaced with the text “CONTINUE”. Select “CONTINUE” and confirm with the OK button when you want to leave the pause mode and start the system. Or, select “STOP” and confirm with the OK button when you want to leave the pause mode and stop the system.

“ADJUST”: The “Run Mode Option Menu” can be reached both when the Model F601 is paused and while it is running. In the “Run Mode Option” menu there are three options: “SETS PER HOUR”, “CLEAR COUNTER” and “PRESET COUNTER”. Scroll/select an option with the arrow buttons and confirm with the OK button.



“SETS PER HOUR”: Change the number of sets per hour using the arrow buttons. The range is 1000 to 3600 sets per hour. Default value is 1800. The speed will however be limited to match units attached.

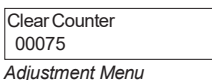

“CLEAR COUNTER”: Clears the set counter when the OK button is pressed.

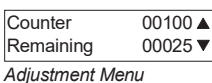

“PRESET COUNTER”: Change the value of the preset counter using the arrow buttons. Default value is 0. This menu can also be used to check the setting of the preset counter and the number of sets to go before the job is completed.

**NOTE: When checking, use the “ESC” button to leave the menu without changing the settings.**

## 2.4 Explanation of the menus (continued)

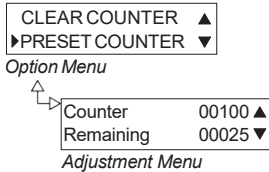

Scrolling down from the “Start Menu”, using the arrow buttons, you will find several options. Press the OK button at the desired option to enter the corresponding “Adjustment Menu” as illustrated in the figure to the left. How each adjustment menu works in detail will be described later in this text. After adjustment, press the OK button to confirm changes or the ESC button to cancel. In either case you will be returned to the “Option Menu”.

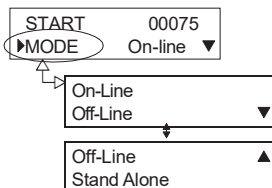

Decide whether the Model F601 should be on-line or off-line with the system or function as a stand alone unit (not applicable to Pitney Bowes models).

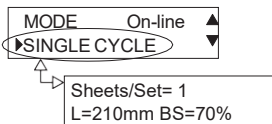

This menu provides information on basic settings, number of sheets per set, insert length and belt speed. No changes can be made here.

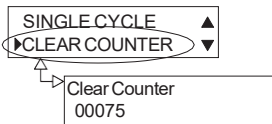

Clears the set counter when the OK button is pressed.

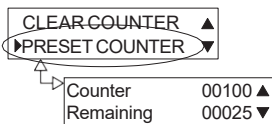

Enter the number of sets for the preset counter using the arrow buttons. Default value is 0. This menu can also be used to check the setting of the preset counter and the number of sets to go before the job is completed.

**NOTE: When checking, use the “ESC” button to leave the menu without changing the settings.**



# The Feeder

## 2.4 Explanation of the menus (continued)

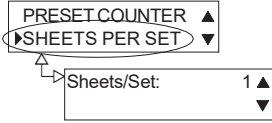

Enter the number of sheets that should be fed from the Model F601 per set using the arrow buttons. The range is 1 to 45 sheets per set. Default value is 1. If running on-line with the Model F610, multiple sheets per set should only be run portrait.



Enter the length of the inserts (in the feed direction) using the arrow buttons. The range is 100 to 310 mm. Default value is 200 mm. Use the scale attached to the unit to measure the length of the booklet.

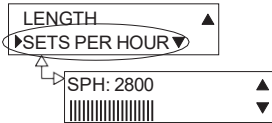

Enter the number of sets per hour using the arrow buttons. The range is 1000 to 3600 sets per hour. Default value is 1800. The speed will however be limited to match units attached. When running the machine do not change speed by more than 1000 SPH at a time, it can create interruption.

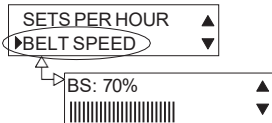

Belt speed is how fast each insert will be fed. Adjust to determine the position of the booklet on the Model F610. Enter a percentage using the arrow buttons. The range is 60 to 100%. Default value is 80%. If the belt speed is too slow the inserts might have problems to “leaving” the Model F601. If the belt speed is too high, single sheets might turn over when they are fed and booklets might bounce back.

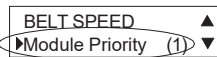

Module Priority is similar to the ID number and decides the order of the inserts in the envelope. Lowest number feeds first and so on. For example, the table on page 5 shows that the Model F601 feeds first and then the Model F612/F615.

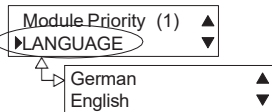

Select language using the arrow buttons.

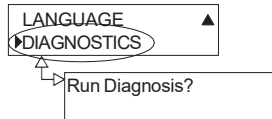

Starts the self diagnosis when the OK button is pressed. Memory, sensors, feed belt motor and the voltage supplied is checked.

See section 6 for error messages, explanations and actions to be taken.

## 3. OPERATION

### 3.1 Setting up the Model F601

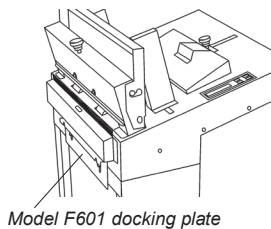
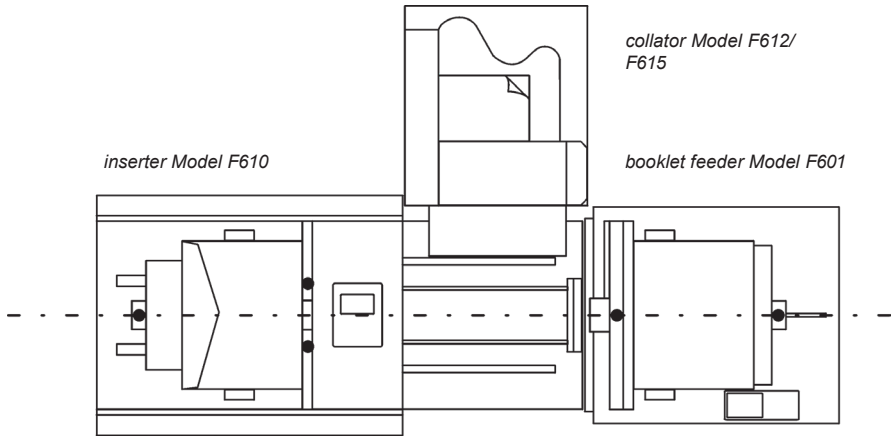

Lift the Model F601 docking plate and position the Model F601 up to the Model F610. Ensure that the docking plate locks the Model F601 to the Model F610. If a Model F612/F615 Collator is present in the system, it should be positioned in the docking plate on Model F610. While calibrating the collator, adjust the paper deflector so that the leading edge of the sheets lands between the insert feed belts on the Model F610 document table.

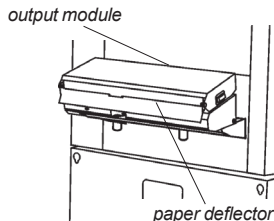

To exclude the Model F601 from the system, just select "Off-line" from the "Mode" option.

To reactivate, select "On-line" from the "Mode" option.

To exclude the Model F612/F615 from the system, just select "Stacking mode" on the control panel.

To reactivate, select "Third party device mode" on the control panel.

# Operation

## 3.2 Adjusting the separation

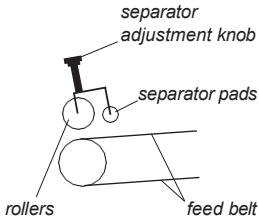

The illustration to the left shows schematically how the separation works and the name of the different parts. Tightening the separator adjustment knob moves the bearing rollers and the separator pads closer to the feed belt. Adjust the separation as follows.

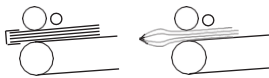

### Booklets over 3 mm thickness

Place the booklet between the bearing rollers and the feed belt as shown in the illustration. Tighten the separator adjustment knob until the feed belts move when the booklet is pulled back and forth.

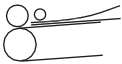

### Single sheets and booklets up to 3 mm thickness

First, place two sheets/booklets between the bearing rollers and feed belt. Tighten the separator adjustment knob so the two rollers are parallel. Pull the two sheets/booklets so they are now between the separator pads and the feed belts as shown in the illustration. Tighten the separator adjustment knob. Grab only the top sheet and keep it stretched. Then release until the top sheet can be pulled out.

Adjustment can be checked from the Module Priority menu. Press the up arrow button to feed step by step. To feed an entire set, press the OK button. Repeat pressing OK while fine turning adjustment if needed.

## 3.3 Loading

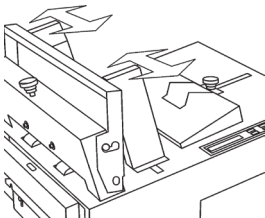

side guide adjustment

Slide the insert side guides away from each other. Load the inserts. Slide the guides towards and up against the inserts. First place one insert under the separation, then load the rest of the stack. Make sure each insert is up against the front guide.

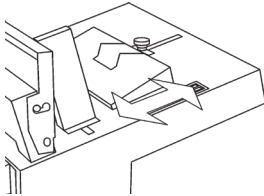

*rear guide adjustment*

The adjustment of the rear guide affects the friction between the inserts and the feed belt. Adjustment therefore depends on paper weight, structure and printing method as well as what type of inserts are being fed. Proper adjustment is more significant when running single sheets. Loosen the knob and slide the rear guide to adjust. Tighten after adjustment. Start with the rear guide to the left and work to the right until proper feed is obtained.

Adjusting the rear guide too much to the left may cause inserts not to be fed due to lack of friction. The error message “Belt overload” will be shown in the display. Move the rear guide to the right to increase the friction.

Adjusting the rear guide too much to the right may cause the next insert to follow directly after the first one. The error message “Paper jam” will be shown in the display. Move the rear guide to the left to decrease the friction.

Proper adjustment of the rear guide demands that the separation is properly adjusted. Detach the rear guide pusher when running booklets. When running single sheets, move the rear guide to the left so the trail edge of the sheets are up on the slop of the pusher. This increases the feed of the sheets.

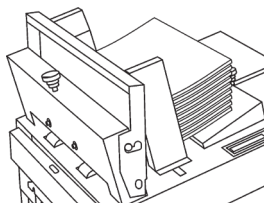

*front guide in rightmost position*

The insert front guide should be positioned in its rightmost position when booklets over 3mm thick are fed. For single sheets and booklets up to 3mm thick, position the front guide in its leftmost position. Lift the front guide to adjust.

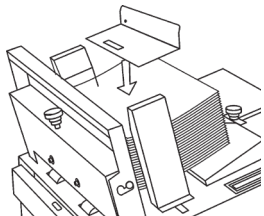

*front guide in leftmost position*

Add additional weight for sheets or inserts which are difficult to feed, or when the stack of paper is low.

# Operation

---

## 3.4 Programming the Model F601

Switch on the power. Select “Mode” and press the OK button. Choose “On-line” if the Model F601 is used together with a Model F612/F615 collator and/or a Model F610 inserter. Choose “Stand Alone” to use the Model F601 as a stand alone booklet feeder. To make the Model F601 inactive, choose “Off-line”. Confirm your choice by pressing the OK button.

Select “Sheets per set” and press the OK button. Enter number of sheets per set using the arrow buttons. The range is 1 to 45 sheets per set. Default value is 1. Confirm by pressing the OK button. If running on-line with a Model F610, multiple sheets per set should only be run portrait.

Select “Length” and press the OK button. Enter the length of the inserts (in the feed direction) using the arrow buttons. The range is 100 to 310 mm. Default value is 200 mm. Confirm by pressing the OK button. Use the scale attached to the unit to measure the length of the booklet.

Select “Sets per hour” and press the OK button. Enter the number of sets per hour using the arrow buttons. The range is 1000 to 3600 sets per hour. Default value is 1800. The speed will however be limited to match units attached. Confirm by pressing the OK button.

Select “Belt speed” and press the OK button. Enter a percentage using the arrow buttons. The range is 60 to 100%. Default value is 80%. Confirm by pressing the OK button.

Select “Module Priority”. If necessary, change the feeding order (ID number) by pressing the OK button. Lowest number feeds first and so on. Leave the “Module Priority” option menu using the ESC button.

If you wish to reset the set counter select “Clear counter” and press the OK button. The next menu shows the actual value of the set counter. Clear the set counter by pressing the OK button.

If you wish to program a specific number sets for a job, select “Preset counter” and press the OK button. The next menu shows the actual value of the preset counter and how many more sets to go to finish the job. Enter a new value using the arrow buttons. Default value is 0. Confirm by pressing the OK button.

Pressing ESC anywhere in the option menu, takes you to the top of the menu.

## 3.5 Start inserting

After setting up attached units according to their respective operator instructions, the system is ready to be started. The system can be started and stopped using the start and stop buttons on any unit in the system.

## 4. DIAGNOSTICS

### 4.1 The Diagnostics function

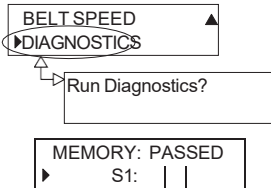

*Example: Display shows that the Model F601 passed the memory test and testing of sensor S1 is in progress.*

**Note: Before starting the diagnostics, all inserts must be removed.**

Select “DIAGNOSTICS” from the “Options Menu” and press the OK button at the “Diagnostics Menu” to start the self test.

The self test will check: memory, insert sensor (S1), outfeed sensor (S2), voltage supplied from the power pack and feed belt motor (M1). During the test, the display will show which part is currently being tested. After the test, you can scroll with the arrow buttons to check that all parts diagnosed, passed the test.

If either of the sensors should fail the diagnostics, check if they are contaminated. If so, clean them and perform the self test again. If cleaning does not correct the problem, or if any other of the parts checked fails the test, have the Model F601 checked by a qualified technician.



The self test is indicated with a flashing “TEST” until the test is completed.

## 5. MAINTENANCE

### 5.1 Cleaning the feed belts

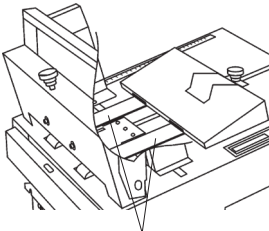

insert feed belts

Clean the insert feed belts using a mild soap detergent every 10,000 feeds or when belts lack friction.

# Problems?

## 6. PROBLEM SOLVING

### 6.1 General Problems

Displayed message	Possible causes	Explanation/action
<div style="border: 1px solid black; padding: 5px;">                     ▶WARNING Comm. Error                 </div>	1. Model F601 started in off-line or on-line mode when Model F610 is powered off. 2. Communication cable between Model F610 and Model F601 not connected or defective. 3. Communication box defective. 4. The Model F612/F615 is switched off or the Comm-Box is not connected.	Communication between the units in the system could not be established. 1. Switch the Model F610 on. 2. Check/replace communication cable. 3. Have the communication box/system checked by a qualified technician. 4. Turn on the Model F612/F615 and set the machine ON-line or OFF-line. Connect the Comm-Box
<div style="border: 1px solid black; padding: 5px;">                     ▶ERROR      Reset ▲ Paper Jam                 </div>	1. Incorrect insert length entered. 2. Double feed because of incorrectly adjusted separation. 3. Double feed because rear guide is adjusted too much to the right. 4. Insert length incorrectly set. 5. Outfeed sensor defective or dirty.	Insert/s not reported fed properly to the Model F610 document table. 1. Enter the correct insert length, in millimeters (see section 2.4). 2. Adjust separation (see section 3.2). 3. Adjust the rear guide (see section 3.3). 4. Sensor may be contaminated with dust. Check/clean the outfeed sensor. Run "Diagnostics" to verify status of sensor. If the self test verifies that the sensor is defective, have the Model F601 checked by a qualified technician. Press the up arrow button to reset the insert/s. Press the Esc button once to enter the single cycle menu. Check what insert length is entered. Press the Esc button once more to enter the start menu.
<div style="border: 1px solid black; padding: 5px;">                     ▶ERROR      Reset ▲ Belt over load                 </div>	1. No inserts fed because of incorrectly adjusted separation. 2. Misfeed because rear guide is adjusted too much to the right. 3. Misfeed because of improper use of the rear guide pusher. 4. Outfeed sensor defective. 5. Feed motor defective.	The outfeed sensor has not sensed any inserts reaching it. 1. Adjust separation (see section 2.4). 2. Run "Diagnostics" to verify status of sensor. If the self test verifies that the sensor is defective, have the Model F601 checked by a qualified technician. 3. Run "Diagnostics" to verify status of feed motor. If the self test verifies that the motor is defective, have the Model F601 checked by a qualified technician. Press the up arrow button to purge the insert/s. Press the Esc button once to enter the single cycle menu. Press the Esc button once more to enter the start menu.

## 6.1 General Problems (continued)

Displayed message	Possible causes	Explanation/action
▶WARNING   Reset ▲ Feeder is empty	<ol style="list-style-type: none"><li>1. No inserts.</li><li>2. Inserts do not cover the sensor on the insert table.</li><li>3. Insert sensor defective.</li></ol>	<p>It is not registered that there are any inserts on the insert table.</p> <ol style="list-style-type: none"><li>1. Reload.</li><li>2. Check that the inserts are loaded properly (see section 3.3).</li><li>3. Run "Diagnostics" to verify status of sensor. If the self test verifies that the sensor is defective, have the Model F601 checked by a qualified technician.</li></ol>
▶System ERROR Interlock at (X)	<ol style="list-style-type: none"><li>1. Interlock switch at unit with ID number "X" is actuated.</li></ol>	<p>See section 2.4 to identify which unit is causing the problem.</p> <ol style="list-style-type: none"><li>1. Check that the interlock switches are not actuated. If problem cannot be corrected, have the system/unit checked by a qualified technician.</li></ol>
▶System ERROR Jam at (X)	<ol style="list-style-type: none"><li>1. Jam at unit with ID number "X" is sensed.</li></ol>	<ol style="list-style-type: none"><li>1. Clear jam at unit "X". If necessary, see section 2.4 to identify which unit is causing the problem.</li></ol>



# Specifications

---

## 7. SPECIFICATIONS

### 7.1 Model F601 Specifications

		Model F601
Paper size	Min	140 x 210 mm
	Max	310 x 310 mm
Paper weight	Min	60 gsm
	Max	Up to 600g total weight of insert
Speed		Up to 3600 sets per hour
Max insert thickness		8 mm
Misfeed detection		Yes
Jam detection		Yes
Height		1020 mm
Width		510 mm
Depth		480 mm
Weight		36 kg
Voltage		36VDC supplied from Power Pack in Model F610

The machine design and specifications are subject to change without notice

We have made every reasonable effort to assure the accuracy and usefulness of this guide, however we cannot assume responsibility for errors or omissions or liability for the misuse or misapplication of our products.

**FOR SERVICE AND SUPPLIES:**



3001 Summer Street, Stamford,  
Connecticut 06926  
[www.pitneybowes.com](http://www.pitneybowes.com)